



**2" OD TUBES
2-1/2" OD TUBES
3" OD TUBES**

COMBINATION BEADING EXPANDER



OPERATING INSTRUCTIONS & SERVICE MANUAL

Rev: A, 2/23/2007

**TO REDUCE THE RISK OF INJURY AND EQUIPMENT DAMAGE
USER MUST READ AND UNDERSTAND OPERATOR'S MANUAL.**

Thomas C. Wilson, Inc.

21-11 44th Avenue, Long Island City, New York 11101
Tel: (718)729-3360 Fax: (718)361-2872 <http://www.tcwilson.com>
E-mail: tcwilson@tcwilson.com

SAFETY INSTRUCTIONS



WARNING!

READ AND UNDERSTAND ALL INSTRUCTIONS

Failure to follow all instructions listed below, may result in accident, fire and/or personal injury.

SAVE THESE INSTRUCTIONS

1. Eye protection is always required when running motor.
2. Hearing protection is recommended when in close proximity to all operating air motors.
3. Dust mask, non-skid safety shoes, hard hat, gloves and other personal safety equipment must be used.
4. Stay alert, watch what you are doing, and use common sense when operating a power tool.
5. Dress properly. Do not wear loose clothing or jewelry.
6. Keep your work area clean and well lit.
7. Disconnect the tool from the air supply before installing, making any adjustment, changing accessories, servicing or storing tool.

OPERATION

Guide Rules For Successful Operation

Be sure expander has the proper guide roll and beading roll for given tube O.D. and gauge to be expanded. See chart below, where 'XX' represent tube gauges. Both tool and tubes must be totally free of scale, anti-rust, and oil. The Wilson B-Kool is recommended for maximum expansion roll traction.

Tube O.D.	X Ga.	Expander No.	Beading Roll		Guide Roll No.
			No.	Dia.	
2	XX	41633-00XX	41631-00XX	5/8	41701-00XX
2-1/2	XX	41634-00XX	*41651-00XX	7/8	41702-00XX
3	XX	41359-00XX	*41666-00XX	7/8	41703-00XX

* Not interchangeable between 2-1/2" or 3" tubes.

Steps For Successful Operation:

Step 1 - Set the tube projection to a nominal

2" projection = (0.187 - 0.200" max.)

2-1/2" tubes projection = (0.200 - 7/32" max.)

3" projection = (0.200 - 7/32" max.)

NOTE : It may be necessary to adjust this amount by + /-1/32" depending on tube GA., sheet hole clearance and total expansion. Also, a bowed or warped tube sheet and tubes cut off with an internal type tube cutter may require projection adjustment. Generally, if the tube projection is not even on a given tube, take measurements on each side of the tube and average them.

Step 2 - Set the Mandrel Stop Nut.

A. Enter the expander into the tube until the beading roll is 1/4" from the tube.

B. Slide mandrel forward for expansion rolls to touch tube I.D.

C. Set mandrel stop nut into position for expansion to be obtained.

D. Example for a 2 1/2" O.D. x 12 gauge tube (.109 wall thickness, with 0.015 sheet hole clearance & 20% wall reduction).

20 % wall reduction = .044

Tube I.D. + 2.282

Clearance + 0.015

Total expansion = 2.341

E. The mandrel stop nut position from the rear bearing is calculated by taking the total expansion .044 (total reduction) and divide by .032 = 1-3/8". Set the nut that distance from bearing face and lock the set screw into groove.

NOTE: To increase expansion .002 turn stop nut counterclockwise (1) turn.

Examples for a 2 1/2" O.D. x 12 gauge tube 5% reduction. (.109 wall thickness)

Tube wall reduction

5 % of .109 x 2 = 0.011

Tube I.D. 2.282

Clearance + .015

Total expansion = 2.308

OPERATION(CONT')

Step 3 -Use a drive of 125-RPM maximum and drive mandrel till stop nut bottoms on thrust bearing. At this point run 2-3 more complete revolutions to relax the tension of the expansion process and iron out the bead area. Use visual means to ascertain the proper amount of revolutions needed to iron out the bead. Too many will flatten the bead; too few will not pull the tube tight against tube sheet. See back sheet for troubleshooting.

Step 4 - KEEP THE TOOL COOL! Submerge tool, Guide Roll down, into Wilson B-Kool (42161-1 quart or 42161-4 gallon) until Beading Roll is covered. Note: Do not submerge Support Roll.

Step 1 – Setting Tube Projection

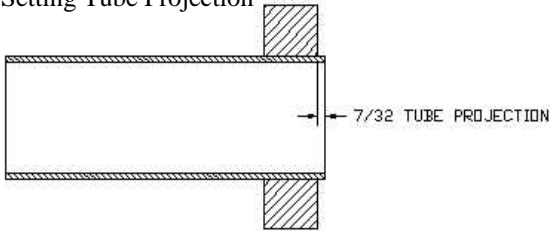

Step 2 – Setting Mandrel Stop

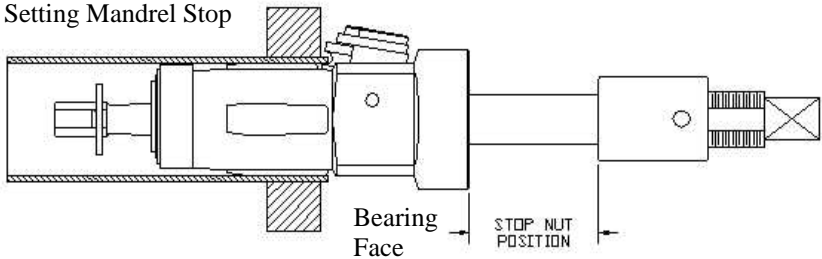

Step 3 – Final Adjustments

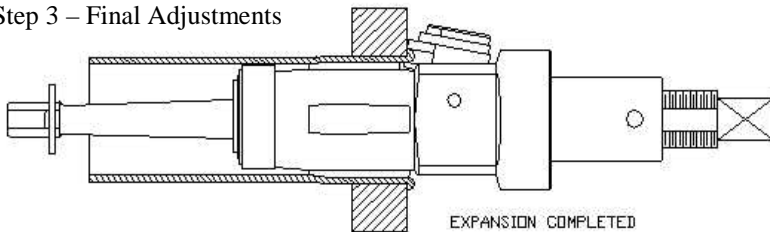

OPERATION(CONT')

Wall Thickness After Expansion Chart								
Tube Wall Reduction	Tube Data							
	Ga.	Wall	Ga.	Wall	Ga.	Wall	Ga.	Wall
	10	.134	11	.120	12	.109	13	.095
10%	.027		.024		.020		.019	
15%	.040		.036		.033		.029	
20%	.054		.048		.044		.038	
25%	.067		.060		.055		.048	
30%	.080		.072		.065		.057	

Boiler Tube Sizing Chart					
Tube O.D. (inches)	Tube Data				
	Ga.	13	12	11	10
	Wall	.095	.109	.120	.134
2	Min.	1.791	1.760	1.736	1.705
	Nom.	1.810	1.782	1.760	1.732
2-1/2	Min.	2.291	2.260	2.236	2.205
	Nom.	2.310	2.282	2.260	2.232
3	Min.	2.791	2.760	2.736	2.705
	Nom.	2.810	2.782	2.760	2.732

Tube Conditions
 Tube Sheet Hole _____
 Tube O.D. _____
 Tube I.D. _____
 Gauge _____
 Wall Thickness _____

Tube Expansion Calculations
 Tube Sheet Hole Dia. _____
 - Tube O.D. _____
 = Clearance _____
 + Tube I.D. _____
 =I.D. @ Metal to Metal _____
 +10%Reduction(Wallx.10x2) _____
 =Expanded I.D. _____
 -original I.D. _____
 =Total Expansion _____

PARTS LIST

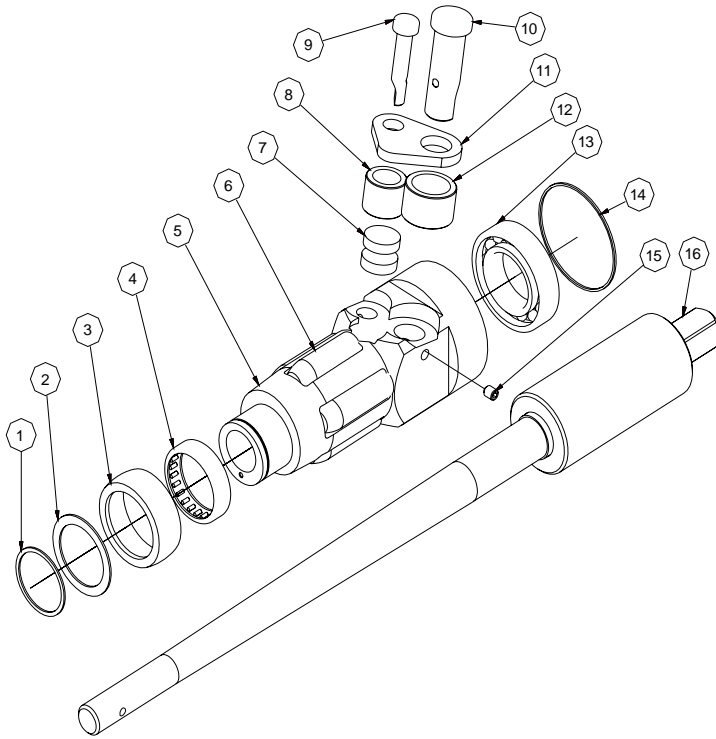

Key	Description	2" Beading Expander 41633-00XX	2-1/2" Beading Expander 41634-00XX	3" Beading Expander 41359-00XX
1	Spirolox	41624	41644	35135
2	Washer	41682	41696	41698
3	Front Guide Roll Ass'y	41701-00XX	41702-00XX	41703-00XX
4	Bearing	41648	41664	41672
5	Cage	42810	41639	41657
6	Expander Roll Set	42811	41673	41676
6a	Roll Set (serialized)	41677	41678	41679
7	Beading Roll	41631-00XX	41651-00XX	41666-00XX
8	Small Support Roll	41669	41668	41668
9	Support Roll Holder-S	41630	41650	41665
10	Support Roll Holder-L	41627	41647	41663
11	Roll Support & Holder	41632	41652	41667
12	Large Support Roll	41668	41671	41674
13	Thrust Bearing	28123	28070	28070
14	Spirolox	34266	34268	34268
15	Set Screw	42395	42395	42393
16	Mandrel	42157	42158	42159

TROUBLE-SHOOTING

Problem	Cause & Solutions
Bead not complete	<ol style="list-style-type: none"> 1. Tube expansion may not be sufficient —Reset the Mandrel Stop Nut. 2. Tube projection not long enough —Increase the tube projection. 3. Anti-rust or mill scale on tube I.D. —Clean tube or expander assembly thoroughly.
Excessive bead formed	<p>Excess tube projection —Decrease the tube projection. Decrease projection by 1/32” until proper bead is formed.</p>
Tube galling or flaking	<p>Excessive heat —Submerge the tool into B-KOOL (part # 42161). Have 2nd unit on hand. Alternate tool after 20-30 tubes.</p>
Cage stops, Mandrel continues to rotate prior to completion of expansion	<p>Excessive heat —Submerge the tool into B-KOOL (part # 42161). Have 2nd unit on hand. Alternate tool after 20-30 tubes.</p>
Needle Bearing failure	<p>Lake of lubrication —Replace and lubricate.</p>
Tube Leakage	<p>Expansion range either too low or tube over expanded — The repair of leaking or bleeding tubes can be accomplished if leakage is not due to over expansion. To seal the joint it is necessary to increase the expansion range from the initial setting. Three to four turns of the Mandrel Nut is a recommended increase. If more is required the nut can be adjusted again. If tube is over expanded it must be removed.</p>

SPECIFICATIONS

O.D.	Ga.	Beading Expander No.	Mandrel Square	Reverse Drive Coupling	Cplg. Hex.	Expansion Range
2	10	41633-0010	3/4" Sq.	42360	9/16" 14.3mm	1.700-1.906" (43.2-48.4mm)
	11	41633-0011				
	12	41633-0012				
	13	41633-0013				
2-1/2	10	41634-0010	3/4" Sq.	42361	3/4" 19.1mm	2.200-2.440" (55.9-62.0mm)
	11	41634-0011				
	12	41634-0012				
	13	41634-0013				
3	10	41359-0010	1" Sq.	42362	7/8" 22.2mm	2.700-2.940" (68.6-74.7mm)
	11	41359-0011				
	12	41359-0012				

TOOL MAINTENANCE

REPLACING BEADING ROLL

When replacing Beading Roll, make sure it is installed with the side stamped the word 'TOP' or its part no. facing upward.

LUBRICATION



The tremendous force to simultaneously expand and bead the tubes, results in an extremely heated tool. This requires a proper schedule of maintenance to lubricate the bearings involved to prevent their premature failure. Lubricate the support roll assembly bearings (key 8 & 12) and the front guide roll assembly (key 4) frequently. Apply a good bearing grease through the grease fittings provided in parts (key 5, 9 & 10).

Thomas C. Wilson, Inc.

21-11 44th Avenue, Long Island City, New York 11101

Tel: (718)729-3360 Fax: (718)361-2872 <http://www.tcwilson.com>

E-mail: tcwilson@tcwilson.com