



‘MS’ SERIES

AIR DRIVEN TUBE CLEANER



OPERATING INSTRUCTIONS & SERVICE MANUAL

Rev: A, 2/22/2007

**TO REDUCE THE RISK OF INJURY AND EQUIPMENT DAMAGE
USER MUST READ AND UNDERSTAND OPERATOR'S MANUAL.**

Thomas C. Wilson, Inc.

21-11 44th Avenue, Long Island City, New York 11101
Tel: (718)729-3360 Fax: (718)361-2872 <http://www.tcwilson.com>
E-mail: tcwilson@tcwilson.com

SAFETY INSTRUCTIONS



WARNING!

READ AND UNDERSTAND ALL INSTRUCTIONS

Failure to follow all instructions listed below, may result in accident, fire and/or personal injury.

SAVE THESE INSTRUCTIONS

1. Do not allow corrosive gases or foreign material to enter the motor. Moisture, oil-based contaminants, or other liquids must be filtered out.
2. Do not hold a running motor with your bare hand. Shock from a high-speed motor's vibration may be experienced as a result.
3. Eye protection is always required when running motor.
4. Hearing protection is recommended when in close proximity to all operating air motors.
5. Dust mask, non-skid safety shoes, hard hat, gloves and other personal safety equipment must be used.
6. Stay alert, watch what you are doing, and use common sense when operating a power tool.
7. Dress properly. Do not wear loose clothing or jewelry.
8. Remove adjusting keys or wrenches before turning the tool on.
9. Keep your work area clean and well lit.
10. Do not operate power tools in explosive atmospheres, such as in the presence of flammable liquids, gases, or dust.
11. Disconnect the tool from the air supply before installing, making any adjustment, changing accessories, servicing or storing tool.
12. Do not allow the air motor to 'run free' at high speed with no load. Excessive internal heat build-up, loss of internal clearance and rapid motor damage may result.

OPERATION

RECOMMENDED OPERATING AIR PRESSURE 90 PSI (6.2 BAR)
MAY BE OPERATED AT 80 TO 125 PSI (5.5 TO 8.6 BAR)

How To Set Up The Tube Cleaner:

1. Blow out air line before attaching operating hose in order to remove all dirt, rust, water or other foreign matter.
2. Attach in-line automatic lubricator (optional equipment; see page 5) or Filter, Lubricator & Regulator Assembly to air outlet. Connect operating hose.
3. Blow out the air line and operating hose again.
4. Connect the tube-cleaner air valve (optional equipment; see page 5) to the operating hose.
5. Attach motor to air valve, making sure connection is wrench-tight – but not jammed – to prevent air leakage.
6. Attach the cleaning or brushing tool to Flexible Holder.
7. Using wrench supplied with equipment, attach Universal Joint or Flexible Holder to motor.

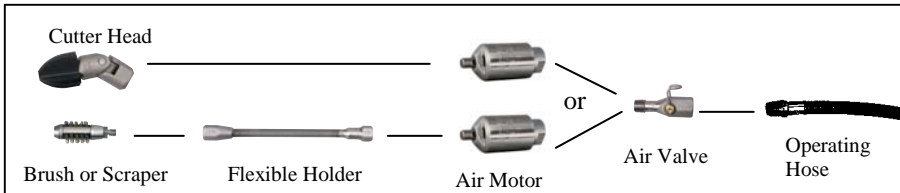

How To Operate The Tube Cleaner:

1. Don't let the cleaning tool run out of the end of the tube – you'll damage it. A good practice is to mark the operating hose with tape or other visible marking to indicate exact length of tube. If tube allows, move motor thru tube first without operating. Then mark length.
2. Insert the cleaning tool into the tube, then open the air valve and feed the motor into the tube slowly enough to properly clean the tube. A method of feed in one foot, back out 6 inches and then feed another foot is a good practice.
3. Keep the motor running when pulling it back through the tube.
4. Shut off the air and stop the motor before taking it out of the tube.
5. If cleaning tool jams in deposit, pull motor back gently to release it. Motor should regain full power. Then feed tool and continue cleaning.
6. If motor functions improperly, it is probably due to faulty lubrication or dirt in the air line. Take motor apart and clean all parts, including the motor blades. See page 5 for disassembly instructions.

PARTS LIST

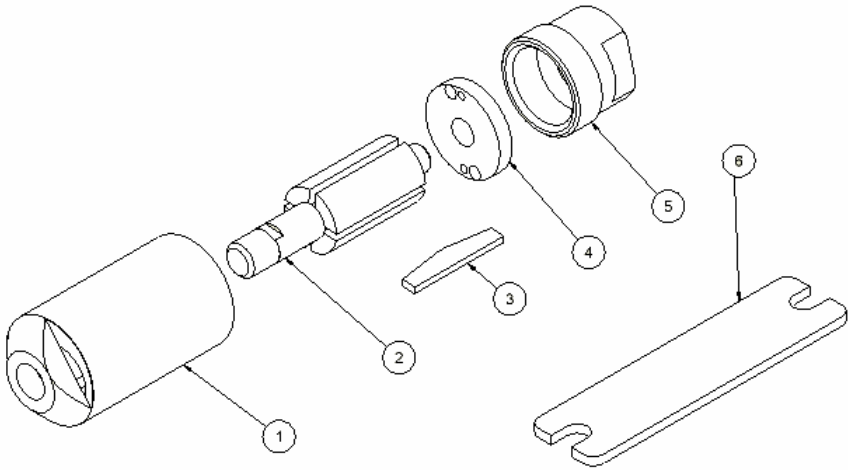

KEY	DESCRIPTION	MS -0	MS -1	MS -1A	MS -3	MS -4	MS -5	MS -6	MS -8	MS -10
	Motor Assembly	2996	3002	3050	8984	8987	8989	8992	8997	8999
1	Body	2998	3004	3052	8986	8988	8991	8994	8998	9000
2	Rotor	2997	3003	2747	8985	2765	8990	8993	2795	2801
3	Blades (set of 4)	3001	3007	2749	2759	2767	2777	2787	2797	2803
4	Bearing	3000	3006	2748	2758	2766	2776	2786	2796	2802
5	Retainer Coupling	2999	3005	3053	6238	9009	6239	6240	6241	9024
6	Rotor Wrench	2057	2057	2001	2016	2016	2028	2031	2031	2031

DISASSEMBLY

How To Change Rotor Blades:

1. Hold Motor Body (key 1) at the flats with a wrench or in a vise and turn Retainer Coupling(key 5) counter-clockwise at the flats with a wrench. Remove Retainer Coupling.
2. Tap front of Rotor (key 2) to push Bearing (key4) and Rotor out from the rear.
3. Remove all four Blades (key 3).
4. Clean and inspect all internal parts for wear, scratch or gouge.
5. To re-assemble, insert Rotor into Motor Body.
6. Insert new Blades into slots of Rotor.
7. Insert bearing over Rotor, making sure pin hole align with locating pin in Motor Body (see following illustration).

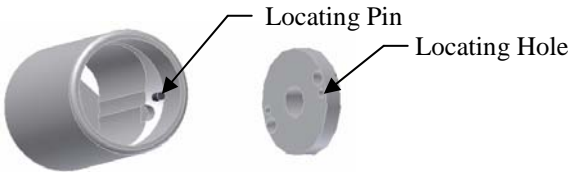

8. Screw on Retainer Coupling and tighten with a wrench just enough so that the Rotor spins freely.
9. Add a few drops of lubricating oil through Retainer Coupling and test-run motor for 5 minutes before applying any attachment.

Air Valve



Pipe NPT	Air Valve
1/4"	9439
3/8"	8774
1/2"	8654
3/4"	8647
1"	8669

Filter-Regulator-Lubricator

Pipe Thread	Manifold Type	Portable Type
1/4" NPT	8905	8905-0250
3/8" NPT	8906	8906-0375
1/2" NPT	8907	8907-0500
3/4" NPT	8908	8908-0750
1" NPT	8909	8909-1000

MAINTENANCE

Lubrication

1. To lubricate motor, use Wilsolube #9047 or synthetic oil .
2. Feed 10 to 20 drops per minute with a automatic lubricator (feed rate is adjustable) depending on the size of motor. This small amount of oil will not coat the tubes. It will be absorbed and blown out with the debris.
3. If you do not have an auto lubricator, use an oil can to apply a few drops of oil into the exhaust ports of the motor. Turn the motor by hand to distribute the oil and then blow out motor before inserting into the tube.
4. Keep motor lubricated at all times.

How to flush a motor

1. Shut off air supply and disconnect the air supply hose for the air motor.
2. Add several teaspoons or spray solvent directly into the motor through the exhaust port.
3. Rotate rotor shaft by hand in both directions for a few minutes.
4. Reconnect the air line and slowly apply pressure until there is no trace of solvent in exhaust air.
5. Flush unit in a well ventilated area.
6. Re-lubricate the motor with a squirt of oil in the chamber.

Storage

1. Before storing your tube cleaner, clean and oil it thoroughly with machine oil to prevent rusting.
2. The best method of storing straight tube motors is to keep them in oil.
3. For curved tube motors, suspend the motor in oil keeping the hose piece above the level of oil as the hose will not stand prolonged immersion in oil.

TROUBLE-SHOOTING

PROBLEM	CAUSE & SOLUTION
Motor is sluggish or inefficient	<ol style="list-style-type: none"> 1. Dirt accumulates inside air motor —Try flushing air motor with recommended solvent. 2. Faulty lubrication —Feed 10 to 20 drops of lubrication oil per minute. 3. Inadequate air pressure —Maintain 80-125 psi pressure.
Motor won't turn	<ol style="list-style-type: none"> 1. Foreign material is present in motor chamber —Take motor apart and clean all parts, including rotor blades. 2. Rotor Blade is broken —Replace if necessary. 3. Bearing was installed incorrectly —See page 5 for assembly instructions
Cleaning tool jams in deposit	Pull motor back gently to release it.

SPECIFICATIONS

Motor Model	Nom. Tube I.D.	Motor Body Dia.	Rotor Thread	Hose & Coupling	C.F.M. at 90 PSI
MS-0	1/2"	15/32"	10-28	3/16 X 1/4	9
MS-1	5/8"	9/16"	10-28	3/16 X 1/4	10
MS-1A	3/4"	11/16"	12-24	1/4	12
MS-1B	25/32"	11/16"	12-24	1/4	12
MS-3	7/8"	49/64"	5/16X18	1/4	13
MS-4	1"	7/8"	5/16X18	3/8	18
MS-5	1-1/8"	31/32"	3/8X16	3/8	25
MS-6	1-7/32"	1-3/32"	7/16X14	3/8	30
MS-7	1-5/16"	1-17/64"	7/16X14	3/8	35
MS-8	1-1/2"	1-17/64"	7/16X14	3/8	35
MS-10	1-3/4"	1-9/16"	7/16X14	3/8	40

Thomas C. Wilson, Inc.

21-11 44th Avenue, Long Island City, New York 11101
 Tel: (718)729-3360 Fax: (718)361-2872 <http://www.tcwilson.com>
 E-mail: tcwilson@tcwilson.com