



42741, 2" OD
42742, 2-1/2" OD
42743, 3" OD

HYDRAULIC TUBE CUTTER



OPERATING INSTRUCTIONS & SERVICE MANUAL

Rev: A, 2/23/2007

TO REDUCE THE RISK OF INJURY AND EQUIPMENT DAMAGE
USER MUST READ AND UNDERSTAND OPERATOR'S MANUAL.

Thomas C. Wilson, Inc.

21-11 44th Avenue, Long Island City, New York 11101
Tel: (718)729-3360 Fax: (718)361-2872 <http://www.tcwilson.com>
E-mail: tcwilson@tcwilson.com

SAFETY INSTRUCTIONS



WARNING!

READ AND UNDERSTAND ALL INSTRUCTIONS

Failure to follow all instructions listed below, may result in accident, fire and/or personal injury.

SAVE THESE INSTRUCTIONS

1. **KNOW YOUR POWER TOOL.** Read this service manual carefully.
2. **GROUNDING INSTRUCTIONS.** This product is equipped with a cord having an equipment-grounding conductor and a grounding plug. The plug must be plugged into an appropriate outlet that is properly installed and grounded in accordance with all local codes and ordinances.
3. **KEEP GUARDS IN PLACE** and in working order.
4. **KEEP WORK AREA CLEAN.** Cluttered areas and benches invite accidents.
5. **AVOID DANGEROUS ENVIRONMENT.** Keep work areas well lit.
6. **STORE IDLE TOOLS.** When not in use, tools should be stored in dry, high or locked-up place – out of reach of children.
7. **DON'T FORCE TOOLS.** It will do the job better and safer at the rate for which it was designed.
8. **USE RIGHT TOOLS.** Don't force small tool or attachment to do the job of a heavy-duty tool.
9. **WEAR PROPEL APPAREL.** No loose clothing or jewelry to get caught in moving parts. Rubber gloves and footwear are recommended when working outdoors.
10. **USE SAFETY GLASSES** with most tools. Also face or dust mask if cutting operation is dusty.
11. **DON'T ABUSE CORD.** Never carry tool by cord or yank it to disconnect from receptacle. Keep cord from heat, oil and sharp edges.
12. **SECURE WORK.** Use clamps or a vise to hold work. It's safer than using your hands to operate tool.
13. **DON'T OVERREACH.** Keep proper footing and balance at all times.
14. **MAINTAIN TOOL WITH CARE.** Keep tools sharp and clean for best and safest performance. Follow instructions for lubricating and changing accessories.
15. **DISCONNECT TOOLS:** When not in use; before servicing; when changing accessories such as blades, bits, cutters, etc.
16. **REMOVE ADJUSTING KEYS AND WRENCHES.** Form habit of checking that keys and adjusting wrenches are removed from tool before turning it on.
17. **AVOID ACCIDENTAL STARTING.** Don't carry plugged-in tool with finger or switch.
18. Remove the plug from the socket before carrying out any adjustment, servicing or maintenance.
19. Do not use unit with combustible fluids or where combustible fluids or fumes may be present.

OPERATION

Guide Rules For Successful Operation

Prior to inserting the tool into a tube, be sure that it has the proper guide rolls for given tube O.D. and gauge to be expanded. See chart below, where 'XX' represent tube gauges. Guide Rolls are marked with tube size for easy identification.

Tube O.D. X Ga.	Hydraulic Tube Cutter	Guide Rolls (Set of 2)	Cutter Wheel	Cutter Pin	
2	XX	42741-00XX	42366-00XX	42752	42754
2-1/2	XX	42742-00XX	41735-00XX	42753	42755-0001
3	XX	42743-00XX	41771-00XX	42753	42755-0001

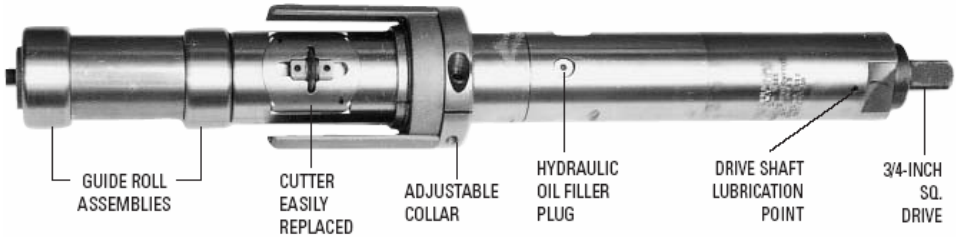

Both tool and tubes must be totally free of scale, anti-rust, and oil for the tool to operate properly.

Steps For Successful Operation:

Step 1 - Adjusting Collar position

Determine the tube projection required. Adjust the thrust collar assembly leading face to position centerline of cutter wheel for distance required. Tighten set screw with 1/8" hex. Key supplied.

Step 2 - Select a drive

Wilson's air-driven reversible roller model 910-1200, 909-1700 & 909-2100 and electric model 41238 & 22488 are recommended. Female 3/4" square coupling will be needed such as 20065, 53777 and 20211.

Step 3 - Operation

Insert Hydraulic Tube Cutter into the tube and position so that thrust collar's leading face is against the tube sheet face. Maintaining contact, activate the drive at drive shaft square. It will provide the input force to provide a radial force to the cutter

OPERATION

Step 3 –(Cont’) forcing it upward into the contact and penetration of the tube wall and provide a torque reaction to rotate the cutter around the inner circumference of tube. After approximately 10 seconds, the remaining tube wall will be thin enough to be penetrated by the rotational force of the cutter wheel completing the cut. To retract the cutter wheel, reverse rotation to retract cutter (approx. 3 seconds). Complete cycle from start to finish is approximately 13 seconds. Cutter is now ready for insertion in next tube.

LUBRICATION & MAINTENANCE

(Check after 2 hours of operation or 250 cuts)

- Lubrication of Drive Shaft
 - a. Find oil plug (set screw) in End Cap near operator end of tool.
 - b. Remove set screw and add 6 drops of machine oil. Note: Make sure dust and dirt (contamination) does not fall into oil hole.
 - c. Secure oil plug back into position.
- Lubricate and clean the piston and cutter wheel area. Remove any dust and dirt build up then lubricate the cutter wheel and the pin with several drops of machine oil.
- Inspect the cutter wheel for heat marks. If necessary use lubrication during cutting to help heat dissipation.
- Clean the cutter often and store it only after cleaning and lubricating.

MAINTENANCE & SERVICE

To change Guide Rolls (Ref. Page 8/9)

- a. Remove socket head cap screw (1) and roll retainer (2) at end of tool. Remove guide rolls (3) and spacer (4).
- b. Install correct size guide rolls and secure cap screw and roll retainer in place. Note: Guide Rolls are marked for size identification.

To check Hydraulic oil level in tool

- a. Turn drive shaft counter-clockwise until cutter piston bottoms.
- b. Slowly turn drive shaft clockwise. There should be no more than one complete turn of the drive shaft before cutter piston moves outwards. If the cutter piston doesn't move after one turn of the drive shaft, the tool is likely to be low on hydraulic oil.

MAINTENANCE & SERVICE

To add Hydraulic oil in tool

- a. Hold hydraulic tube cutter with oil filler plug face up in a vise.
- b. Turn drive shaft counter-clockwise until cutter piston is totally retracted.
- c. Remove filler plug and fill with Hydraulic oil (Texaco-Rando-Oil HD-32 or Black Bear Grade 2X (SAE 10).
- d. Replace filler plug. Slowly turn drive shaft clockwise until drive shaft stops.
- e. Turn drive shaft counter-clockwise until cutter piston is totally retracted.
- f. Remove filler plug and slowly turn drive shaft clockwise until oil comes out and add more oil while slowly retracting drive shaft until the unit comes to a stop. Prevent air from entering chamber while filling.
- g. Replace filler plug.

To change Cutter Pin or Piston (Ref. Page 7)

- a. Retract piston (3). Turn square on drive shaft counter-clockwise.
- b. Lower piston cap set screws (2), clockwise, into cutter body (11). Use 5/64" hex key for 2" HTC or 3/32" hex key for 2-1/2" or 3" HTC.
- c. Turn piston cap (1) one quarter turn with a spanner wrench** #50261(2") or #50262(2-1/2"&3").
- d. Lift out piston cap from cutter body.
- e. Remove piston from piston cap for cutter pin replacement.
- f. Replace cutter, cutter pin and pin retainer screws.
- g. Place piston and piston seal in place. Orient the piston so that the cutter wheel is parallel to center line of cutter body.
- h. Place piston cap over piston, while guiding springs (4) into holes.
- i. With soft hammer tap piston cap squarely to bottom of cutter body.
- j. Turn piston cap one-quarter turn to original position. Turn set screws (2) counter-clockwise to raise them into position.

** Optional equipment.

MAINTENANCE & SERVICE

To change Cutter Blade (Ref. Page 7)

- a. With cutter (5) in uppermost position, remove two set screws (7), with 1/16" hex key.
- b. Slide cutter pin (6) to one side and remove cutter.
- c. Insert new cutter, re-position cutter pin and replace set screws.

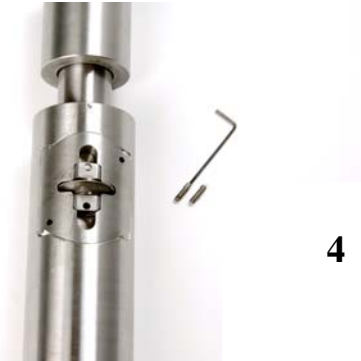
1**2****3****4****5**

PARTS LIST

Cutter Body Assembly

Use spanner wrench to turn Cap
#50261(2") 50262(2-1/2"&3")

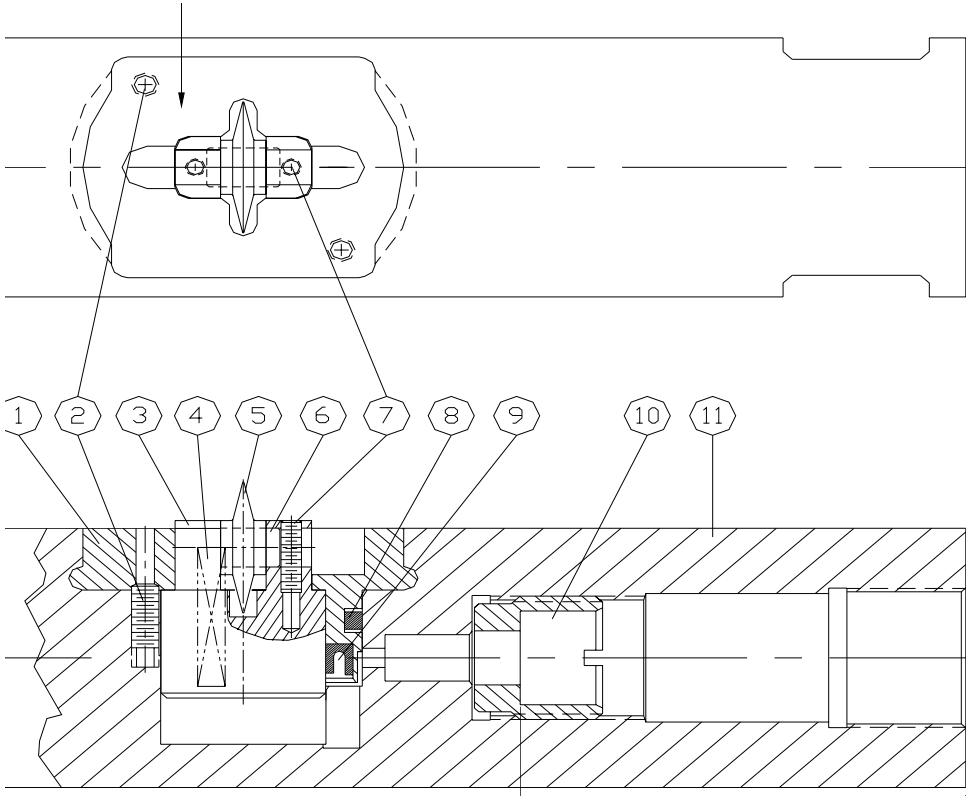

Key	Description	2" HTC	2-1/2" HTC	3" HTC
1	Piston Cap	42760	42761	42788
2	Set Screw	42785	42786	42786
3	Piston	42756	42757	42757
4	Piston Return Spring	42780	42781	42781
5	Cutter	42752	42753	42753
6	Cutter Pin	42754	42755-0001	42755-0001
7	Set Screw	42758	42759	42759
8	Piston Cap Seal	42783	42784	42784
9	Piston Seal	42777	42778	42778
10	Regulator Adjuster	42774	42774	42774
11	Cutter Body	42744	42745	42746

PARTS LIST

Key	Description	2" HTC 41633-00XX
1	Cap Screw	50792
2	Roll Retainer	41728
3	Guide Rolls(2)	42366-00XX
4	Roll Spacer	42749
5	Cutter Body Ass'y (Ref. Page 8)	42744-1000
6	Thrust Collar Ass'y	42798
7	Regulator Spring	42189
8	Regulator Ass'y (Ref. Page 9)	42747
9	Plunger Body Ass'y (Ref. Page 9)	42764-1000
10	Drive End Ass'y (Ref. Page 11)	42199-1000

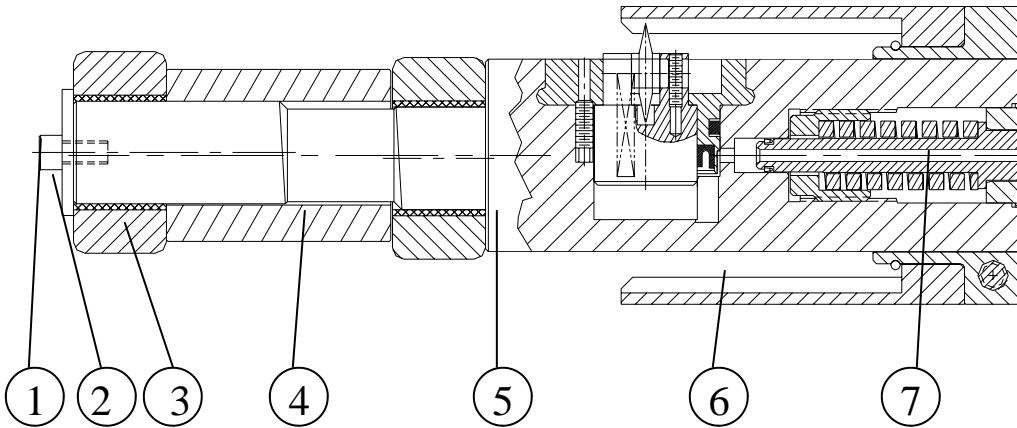

2-1/2" HTC 41634-00XX	3" HTC 41359-00XX
50792	50792
41728	41728
41735-00XX	41771-00XX
42750	42751
42745-1000	42746-1000
42799	42800
42189	42189
42747	42747
42765-1000	42765-1000
42199-1000	42199-1000

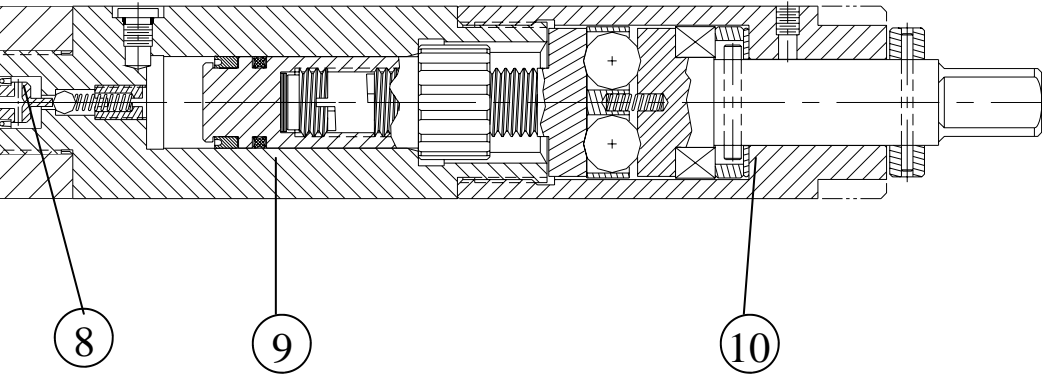

PARTS LIST

Regulator Assembly

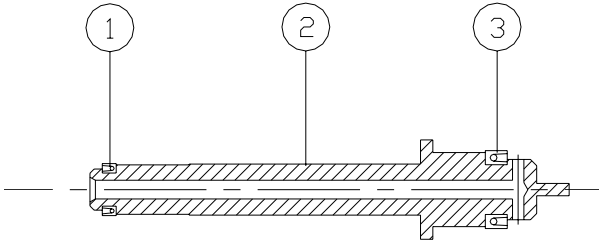

Key	Description	2", 2-1/2" & 3" HTC
1	Seal	42323
2	Regulator Piston	42748
3	Seal	42350

Plunger Body Assembly

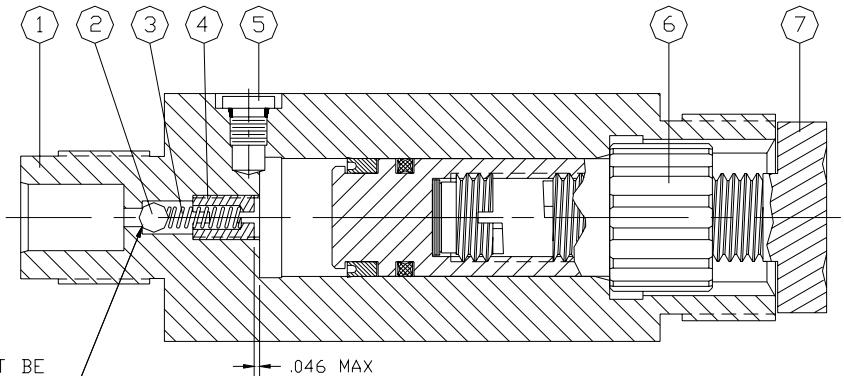

CAVITY MUST BE
CLEAN AND FREE
OF METAL CHIPS

Key	Description	2" HTC	2-1/2" & 3" HTC
1	Plunger Body	42764	42765
2	Valve Ball	24031	24031
3	Valve Spring	42352	42352
4	Spring Retainer	42351	42351
5	Hollow Hex Plug	42400	42400
	O-Ring (part of above)	24295	24295
6	Plunger Assembly	41695	42740
7	Drive Spindle	42775	42775

PARTS LIST

Plunger Assembly & Drive End Assembly

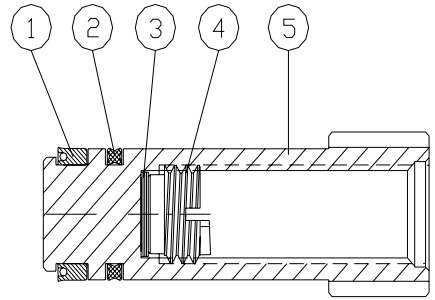

Key	Description	2" HTC	2-1/2" & 3" HTC
1	Poly Pack Seal	41761	41762
2	Quad Ring	21492	21492
3	Shim	42197-0002	42197-0002
4	Spindle Stop	42197	42197
5	Plunger	41763	42766

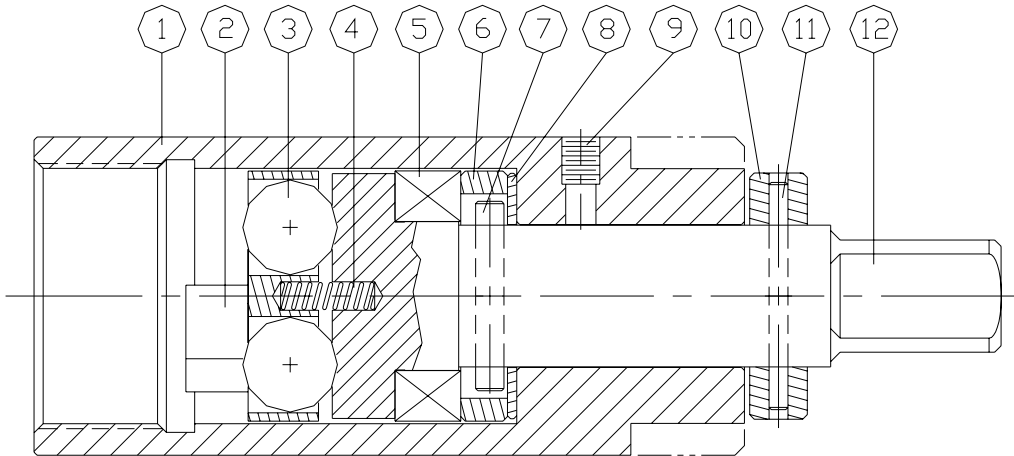

Key	Description	2", 2-1/2" & 3" HTC
1	End Cap	42199
2	Spindle Coupling	42762
3	Release Ball	42776
4	Coupling Spring	42782
5	Thrust Bearing	41915
6	Friction Washer	42773
7	Pin	42402
8	Bronze Washer	42415
9	Oil Plug	6904
10	End Collar	42208
11	Roll Pin	42399
12	Drive Shaft	42763

TROUBLE-SHOOTING

	PROBLEM	POSSIBLE CAUSES	CORRECTION
A	Cutter does not retract and Drive Shaft does not reverse.	<ol style="list-style-type: none"> 1. Worn Plunger (damaged Spindle Stop) 2. Worn bronze washer 	<p>Replace Plunger and/or Spindle Stop</p> <p>Replace Washer</p>
B	Lack of cutting pressure	Seal leaked or damaged.	<p>Check oil plug for leakage.</p> <p>Check Seals (page 8).</p> <p>Check seals (page 11).</p>
C	Binding or roughness in running of tool	<ol style="list-style-type: none"> 1. Lack of lubrication of drive shaft or guide roll bearing. 2. Low hydraulic oil. 3. Valve seat leaking. 	<p>Lubricate drive shaft or guide roll with machine oil.</p> <p>Replace Guide Roll.</p> <p>Add oil thru oil plug.</p> <p>Re-seat valve seat.</p>
D	Tool runs but does not cut	<ol style="list-style-type: none"> 1. Incorrect size guide rolls. 2. Cutter wheel may be dull. 	<p>Use proper size guide roll.</p> <p>Replace cutter.</p>
E	Tube bulges, but cutter doesn't penetrate.	<ol style="list-style-type: none"> 1. Check to see if cutter is dull. 2. Worn cutter pin 3. Cutter Piston rises up too quickly. 	<p>Replace cutter.</p> <p>Replace cutter pin.</p> <p>Check Regulator Adjustor (page 8)</p>
F	Cutter does not retract	<ol style="list-style-type: none"> 1. No friction on guide roll. 2. Low on hydraulic oil 3. Dirt allowed to build up in piston cap where cutter piston and cutter pin travel 	<p>Press tool downward slightly (This will cause friction on guide roll), run in reverse position until tool rotates, then cutter is retracted.</p> <p>Add oil.</p> <p>Flush out with light oil or kerosene and air blow to remove remaining particles of dirt.</p>

Thomas C. Wilson, Inc.

21-11 44th Avenue, Long Island City, New York 11101

Tel: (718)729-3360 Fax: (718)361-2872 <http://www.tcwilson.com>E-mail: tcwilson@tcwilson.com