

SPECIFICATIONS

MODEL	WAM-5500-500 WAM-5520-500	WAM-5500-375 WAM-5520-375
VOLTAGE	115 220	115 220
FREQUENCY	60 50/60	60 50/60
HORSEPOWER	1	1
RPM	1725 1425	1725 1425
SELF FEED RATE	4.2 FT PER SECOND (1.3 m/s)	4.2 FT PER SECOND (1.3 m/s)
SHAFT & CASING	1/2" O.D. (12.70 mm)	3/8" O.D. (9.52 mm)
DIMENSION	42 in x 30 in x 16 in (1067mm x 762mm x 406mm) *excluding gun assembly	42 in x 30 in x 16 in (1067mm x 762mm x 406mm) *excluding gun assembly
WEIGHT	85 lbs (38kgs)	85 lbs (38kgs)

LIST OF ACCESSORIES

Item	Part No.	Description
• Flexible Shaft Lubricator	9675-0000	
• Safety Shaft Coupling	9600-0102	includes removal tool
• Flexible Shaft & Casing	9722-0045	Shaft & Casing, 3/8in OD, 45ft
•	9724-0045	Shaft & Casing, 1/2in OD, 45ft
• Spiral Brushes	61746-x0xx	(Max. Speed = 1725/min.)
•	62501-x0xx	(Max. Speed = 1725/min.)

Thomas C. Wilson, Inc.

21-11 44th Avenue, Long Island City, New York 11101
 Tel: (718)729-3360 Fax: (718)361-2872 <http://www.tcwilson.com>
 E-mail: tcwilson@tcwilson.com



WAM-5500-375/500
 WAM-5520-375/500

WILS-MATIC AUTO TUBE PUNCHER



OPERATING INSTRUCTIONS & SERVICE MANUAL

Rev: A, 10/26/2011

TO REDUCE THE RISK OF INJURY AND EQUIPMENT DAMAGE
 USER MUST READ AND UNDERSTAND OPERATOR'S MANUAL.

Thomas C. Wilson, Inc.

21-11 44th Avenue, Long Island City, New York 11101
 Tel: (718)729-3360 Fax: (718)361-2872 <http://www.tcwilson.com>
 E-mail: tcwilson@tcwilson.com

SAFETY INSTRUCTIONS



WARNING!

READ AND UNDERSTAND ALL INSTRUCTIONS

Failure to follow all instructions listed below, may result in accident, fire and/or personal injury.

SAVE THESE INSTRUCTIONS

1. **KNOW YOUR POWER TOOL.** Read this service manual carefully.
2. **GROUNDING INSTRUCTIONS.** This product is equipped with a cord having an equipment-grounding conductor and a grounding plug. The plug must be plugged into an appropriate outlet that is properly installed and grounded in accordance with all local codes and ordinances.
3. **KEEP GUARDS IN PLACE** and in working order.
4. **KEEP WORK AREA CLEAN.** Cluttered areas and benches invite accidents.
5. **AVOID DANGEROUS ENVIRONMENT.** Keep work areas well lit.
6. **STORE IDLE TOOLS.** When not in use, tool should be stored in dry place.
7. **DON'T FORCE TOOLS.** It will do the job better and safer at the rate for which it was designed.
8. **USE RIGHT TOOLS.** Don't force small tool or attachment to do the job of a heavy-duty tool.
9. **WEAR PROPER APPAREL.** No loose clothing or jewelry to get caught in moving parts. Rubber gloves and footwear are recommended when working outdoors.
10. **USE SAFETY GLASSES** with this tool.
11. **DON'T ABUSE CORD.** Never carry tool by cord or yank it to disconnect from receptacle. Keep cord from heat, oil and sharp edges.
12. **DON'T OVERREACH.** Keep proper footing and balance at all times.
13. **MAINTAIN TOOL WITH CARE.** Keep tool clean for best and safest performance. Follow instructions for changing accessories.
14. **DISCONNECT TOOLS:** When not in use; before servicing; when changing accessories.
15. **REMOVE ADJUSTING KEYS AND WRENCHES.** Form habit of checking that keys and adjusting wrenches are removed from tool before turning it on.
16. Remove the plug from the socket before carrying out any adjustment, servicing or maintenance.
17. Do not use unit with combustible fluids or where combustible fluids or fumes may be present.

TROUBLE-SHOOTING

PROBLEM	CAUSE & SOLUTION
<ul style="list-style-type: none"> • No power • Green Light not lit up when unit is first plugged into power outlet 	<ul style="list-style-type: none"> • GFCI Plug not reset —press reset button on GFCI • GFCI Plug defective • Power cord defective • Green Light (Power On) defective
<ul style="list-style-type: none"> • Power up but motor not turning when activated 	<ul style="list-style-type: none"> • Blown Fuse —replace fuse #1 • Defective motor • Defective wiring in unit • Overload protection engaged on the motor —reset the motor by pressing OLP reset button from the back of the unit. (use the hole next to the fan)
<ul style="list-style-type: none"> • Power up but motor not turning forward when activated 	<ul style="list-style-type: none"> • Stop switch plate damaged and is constantly hitting the forward stop switch.
<ul style="list-style-type: none"> • Motor running but Flexible Shaft not turning 	<ul style="list-style-type: none"> • Broken Safety Coupling • Broken Shaft Cable
<ul style="list-style-type: none"> • Motor running but no water output at end of Flexible Shaft 	<ul style="list-style-type: none"> • Water supply not turn on • Defective Solenoid Valve
<ul style="list-style-type: none"> • Flexible Shaft turning but not feeding out 	<ul style="list-style-type: none"> • Feed wheel not grabbing the shaft • Broken belt • Brush head is getting resistance from inside the tube —Reverse couple of inches and feed forward
<ul style="list-style-type: none"> • Motor running and water drips inside unit <p>Note: Some water coming back from the rotating brush that is collected inside the Feeder Gun Assembly will come out from under the unit. There are 4 drainage holes for this water to drain out of the control unit.</p>	<ul style="list-style-type: none"> • Worn Teflon seal inside Motor Connector • Leakage in tube or tube fittings
<ul style="list-style-type: none"> • Unit running rough and/or noisy 	<ul style="list-style-type: none"> • Lack of lubrication in Motor Connector —grease ball bearings inside Motor Connector • —replace worn or corroded ball bearings in Motor Connector • Loose Covers on the unit

SHAFT & CASING REPLACEMENT

In order to replace the shaft and casing follow these steps:

1. Remove the brush from the Shaft & Casing.
2. Un-screw the shaft from the “Shaft Drive Connector”
3. Reverse the Shaft & Casing until it comes back out from the feed wheel.
4. Remove the “Stop Collar”, “Stop Spring” and the “Spring Cone” from the worn Shaft & Casing then replace it onto the new Shaft & Casing.
5. Feed the new Shaft & Casing in to the machine and then screw the back end of the shaft & casing on to the “Shaft Drive Connector”
6. Attach the new brush and continue on with your cleaning cycle.

MAINTENANCE

- **NOTE:** Remove the plug from the power outlet before carrying out any adjustment, service, or maintenance.
- Safety coupling replacement: A 80 in-lb safety coupling (9600-0102) is supplied within the motor connection assembly. It will break if the shaft is overloaded by forcing the shaft into a clogged tube. A hook-type removal tool (9600-0055) is supplied for removing the broken coupling. Engage the end of of the coupling with this tool and pull it out.
- Storage: To store, disconnect water supply hose and gun assembly. Disconnect flexible shaft from machine. Dry out the shaft with an air blast through a hose fitting (optional 9614) attached to large aluminum coupling. Store the tube cleaner in a dry, heated place.
- Lubrication: Grease ball bearing inside motor connector housing through grease fitting (located inside drive unit) every 200 hours of use.
- Replacement of cords or electrical components: If supply cord is damaged, it must be replaced by an assembly available from the factory.

ASSEMBLY

STEP 1



STEP 2

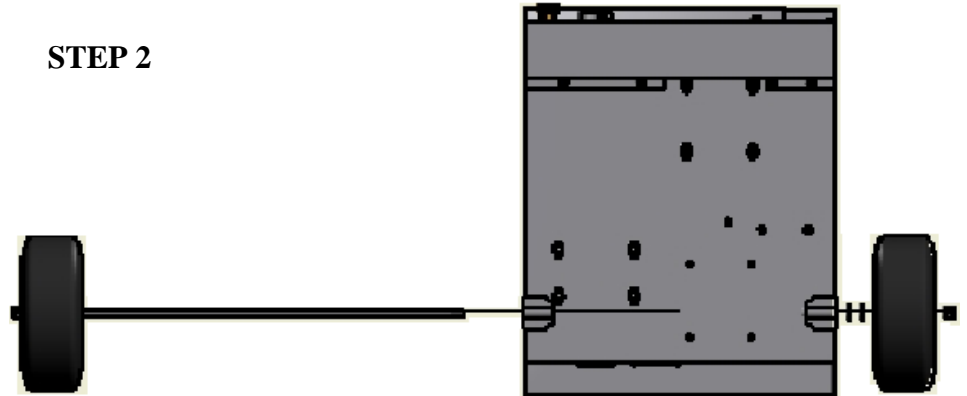

STEP 3

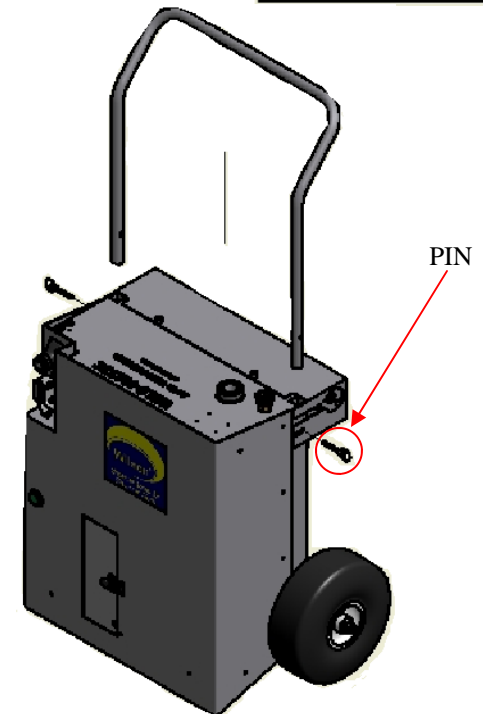

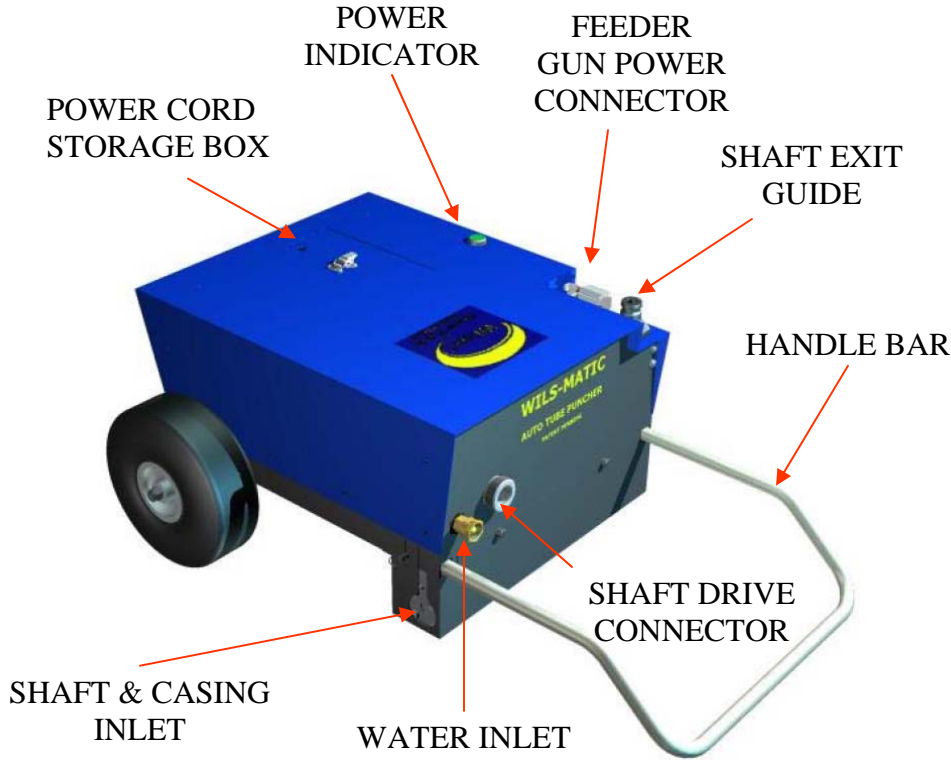

Unit Without Back Cover

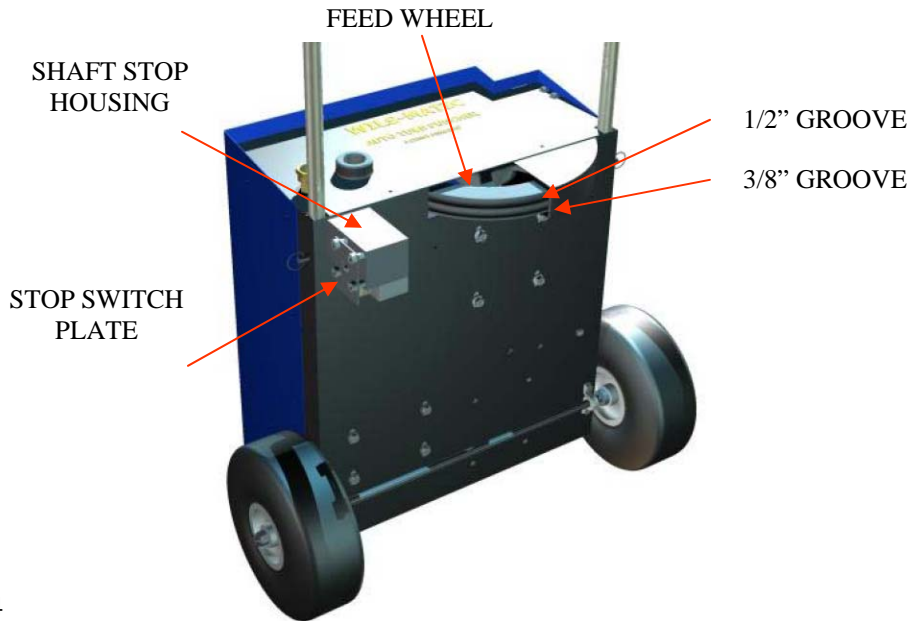

PARTS LIST

ITEM	QTY	PART NUMBER	DESCRIPTION	ITEM	QTY	PART NUMBER	DESCRIPTION
1	1	9600-0400	WATER VALVE ASSY	24	1	9992-1117	STORAGE BOX
2	1	9992-1114	HANDLE	25	1	9992-6910	MOTOR, ELECTRICAL
3	2	9600-0124	QUICK-RELEASE PIN		4	9992-2131	NUT-CLIP ON
4	1	9992-1180	SHAFT EXIT GUIDE		1	9992-5111	V BELT
5	2	9992-1182	5/16-18 HEX SCREW		1	9992-5121	4L PULLEY-2.5" OD
6	1	46000-2110	HARTING CONNECTOR		1	9992-5132	L TYPE COUPLING HUB
7	4	9992-2140	THPMS, #4-40 x 1/2" SS		4	9992-5150	BOLT-FLANGED HEX HEAD
8	1	9992-2190	CONTROL BOX	26	1	9992-5132	L TYPE COUPLING HUB
9	1	9992-1113	FRONT COVER	27	1	9992-5170	3/16 x 3/16 KEYWAY
10	1	9992-1118	LATCH	28	1	9992-5140	5/8" OD SHAFT W/KEYWAY
11	11	9992-1219	SCREW-PAN HEAD	29	1	9992-5133	L TYPE COUPLING SPIDER
12	22	9992-1221	LOCKNUT-SS	30	1	9992-0020	STOP SWITCH SUB ASSEMBLY
13	1	9992-1200	BACK COVER		4	38070-0000	SHOULDER BOLT
14	1	9992-1217	SQUARE COOLING FAN		1	9992-1121	SHAFT STOP HOUSING
15	1	9992-1218	SQUARE FAN GUARD		1	9992-1122	SHAFT STOP PLATE
16	1	9992-1149	WHEEL AXLE	4	9992-1123	STOP PLATE SPRING	
17	2	9992-1126	WHEEL PNEUMATIC	1	9992-1125	GUIDE BUSHING	
18	4	30575-0000	WASHER-1/2"	1	9992-2111	BUSHING-FLANGED LIP	
19	1	9600-0010	2 WAY SOLENOID VALVE	4	9992-2140	SCREW-THRUS HEAD	
20	1	9992-1112	FRAME BASE	1	9992-2156	SWITCH, STOP	
21	1	9600-0106	MOTOR CONNECTOR	2	9992-2158	METAL CONDUIT	
22	1	9992-6950	FEED WHEEL	31	1	9992-2160	FEED WHEEL GUIDE LIP
23	1	9992-6920	GEAR REDUCER (21.54:1)				
	4	30573-0000	WASHER-5/16"				
	4	9618-0000	STOP NUT-1/2"				
	1	9992-5121	4L PULLEY-2.5" OD				
	4	9992-5150	BOLT-FLANGED HEX HEAD				

PARTS LIST

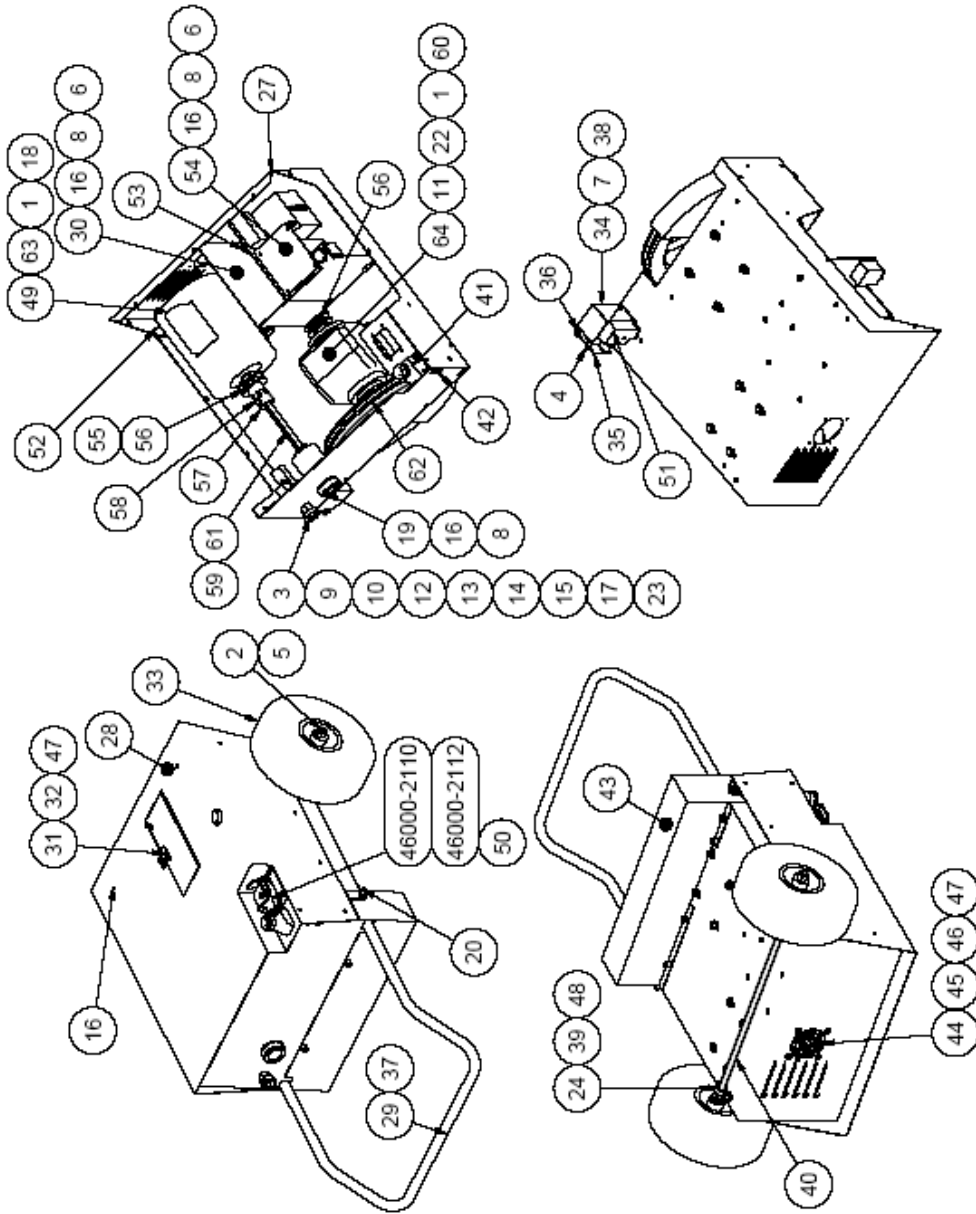

SETUP

STEP 1



STEP 2

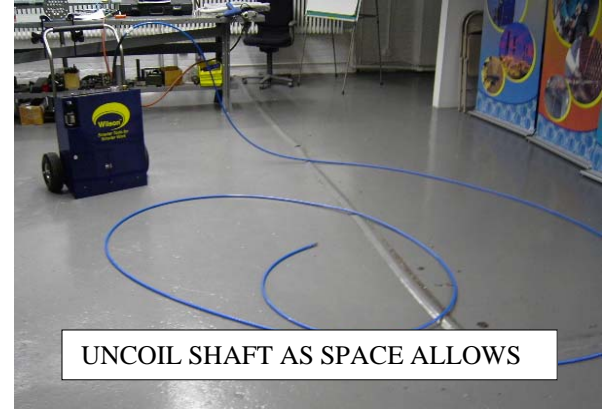

STEP 3



STEP 4



STEP 5



STEP 6



SETUP CON'T

STEP 7

CONNECT
FEEDER GUN
CABLE TO
UNIT



STEP 8

TOGGLE GUN UNTIL
SHAFT IS SLIGHTLY
EXPOSED FROM UNIT



SETUP CON'T

STEP 15

FASTEN SHAFT STOP IN PLACE



STEP 9

ATTACH
FEEDER GUN
COUPLING TO
UNIT



STEP 10

TOGGLE GUN UNTIL
SHAFT IS SLIGHTLY
EXPOSED FROM GUN



OPERATION

STEP 1

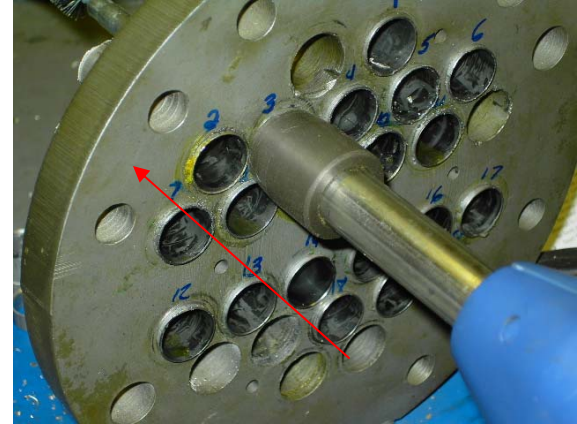

STEP 11

ATTACH BRUSH
TO SHAFT



STEP 12

REPLACE BACK
COVER



STEP 2

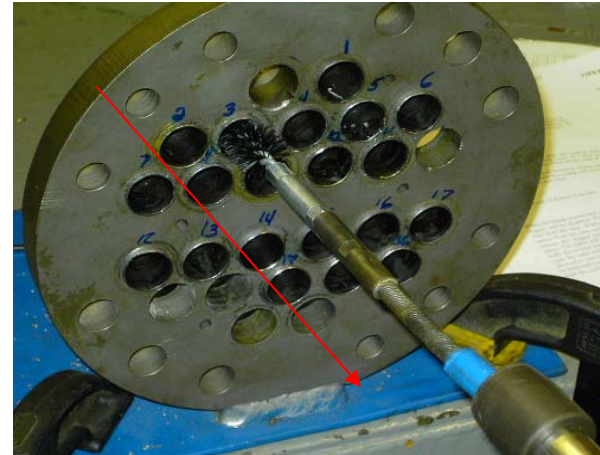

STEP 13

LAY UNIT ON LEVEL GROUND



STEP 14

ATTACH WATER HOSE

