

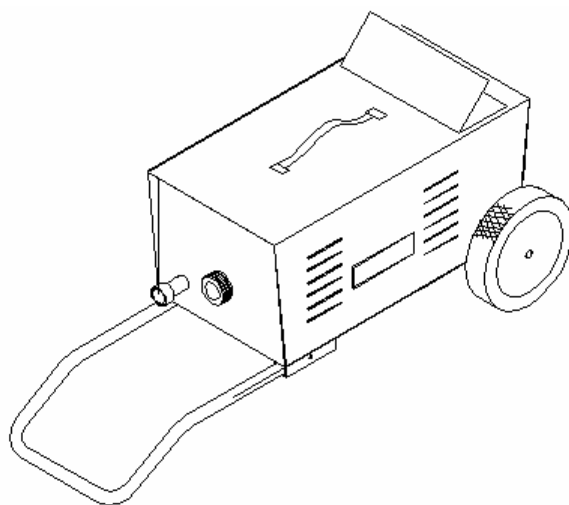

WILS-AWAY PNEUMATIC TUBE CLEANER

MODEL 9800 4 HP 0-1400 RPM



OPERATING INSTRUCTIONS & SERVICE MANUAL

TO REDUCE THE RISK OF INJURY, USER MUST READ AND UNDERSTAND OPERATOR'S MANUAL.

Thomas C. Wilson, Inc.

21-11 44th Avenue, Long Island City, New York 11101
Tel: (718)729-3360 Fax: (718)361-2872 <http://www.tcwilson.com>
Email: tcwilson@tcwilson.com

SAFETY INSTRUCTIONS

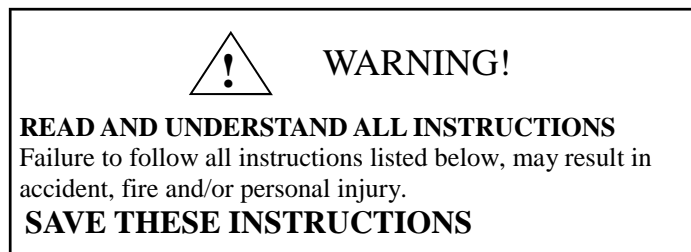

1. **KNOW YOUR POWER TOOL.** Read this service manual carefully.
2. **GROUNDING INSTRUCTIONS.** This product is equipped with a cord having an equipment-grounding conductor and a grounding plug. The plug must be plugged into an appropriate outlet that is properly installed and grounded in accordance with all local codes and ordinances.
3. **KEEP GUARDS IN PLACE** and in working order.
4. **KEEP WORK AREA CLEAN.** Cluttered areas and benches invite accidents.
5. **AVOID DANGEROUS ENVIRONMENT.** Keep work areas well lit.
6. **STORE IDLE TOOLS.** When not in use, tools should be stored in dry, high or locked-up place – out of reach of children.
7. **DON'T FORCE TOOLS.** It will do the job better and safer at the rate for which it was designed.
8. **USE RIGHT TOOLS.** Don't force small tool or attachment to do the job of a heavy-duty tool.
9. **WEAR PROPEL APPAREL.** No loose clothing or jewelry to get caught in moving parts. Rubber gloves and footwear are recommended when working outdoors.
10. **USE SAFETY GLASSES** with most tools. Also face or dust mask if cutting operation is dusty.
11. **DON'T ABUSE CORD.** Never carry tool by cord or yank it to disconnect from receptacle. Keep cord from heat, oil and sharp edges.
12. **SECURE WORK.** Use clamps or a vise to hold work. It's safer than using your hands to operate tool.
13. **DON'T OVERREACH.** Keep proper footing and balance at all times.
14. **MAINTAIN TOOL WITH CARE.** Keep tools sharp and clean for best and safest performance. Follow instructions for lubricating and changing accessories.
15. **DISCONNECT TOOLS:** When not in use; before servicing; when changing accessories such as blades, bits, cutters, etc.
16. **REMOVE ADJUSTING KEYS AND WRENCHES.** Form habit of checking that keys and adjusting wrenches are removed from tool before turning it on.
17. **AVOID ACCIDENTAL STARTING.** Don't carry plugged-in tool with finger or switch.
18. Remove the plug from the socket before carrying out any adjustment, servicing or maintenance.
19. Do not use unit with combustible fluids or where combustible fluids or fumes may be present.

ASSEMBLY

The WILS-AWAY Tube Cleaner may be set up with its built-in dolly for operator convenience. Follow the assembly instructions below:

1. Set the WILS-AWAY on its end with aluminum Motor Connector facing up. Insert the Dolly Handle through square hollow brackets.
2. Insert Clevis Pins through lower hole on both sides.
3. Pull Handle up until it stops and insert the Quick-Release Pin through the bracket and the upper hole of Handle on both sides.
4. Insert Axle through bracket at bottom. Mount wheel onto Axle on both sides.
5. Tighten Stop Nuts with a wrench to secure the wheels. Tighten just enough so that the wheel will spin freely.

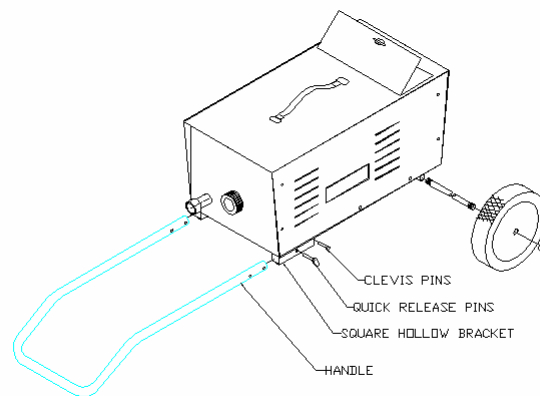

OPERATING POSITION

The WILS-AWAY tube cleaner may be operated with or without the dolly in place. However, it should be only with the top side (side with carrying handle) up, as illustrated below:

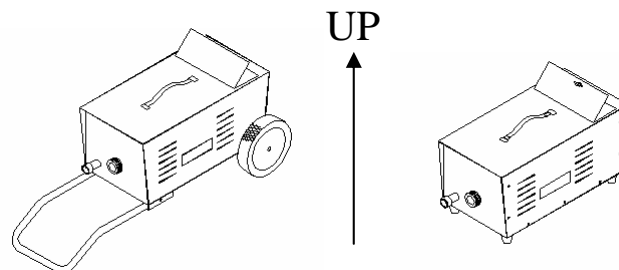

OPERATION

1. Remove electrical cord from storage compartment and plug it in a properly grounded outlet. Press the reset button on the GFCI plug.
2. Flip the main switch on the side panel. The pilot light should go on indicating power is on.
3. Remove foot pedal from box and connect its tube end to air spout on side panel. For single direction applications, connect tube to air spout marked FORWARD (clockwise rotation viewing from back of machine). For bi-direction applications, connect tubes to air spouts according to labels attached. NOTE: Remote air switches operate at alternate action (step on/step off) in FORWARD mode and at momentary action in REVERSE mode.
4. Select flexible Shaft as required for tube size to be cleaned. Uncoil and stretch out to straighten it as much as possible. Pull male Square extending from large aluminum coupling out about an inch. Insert this square into coupling within motor connection on box end. Box may be set on opposite end to facilitate this. Securely hand-tighten large aluminum coupling with seal quad-ring captive within onto motor connector assembly.
5. Connect water hose to water inlet with strainer within. Turn water supply on. Solenoid valve only opens to allow water through when the motor is running.
6. Position hose clamp or place a mark on outside of flexible shaft to retain brush or cleaning head just within tube on opposite end.
7. Place the foot pedal at a point close to the tube sheet. Hold the end of the flexible shaft with one hand about three inches from the cleaning head; making sure it is held away from your body and then depress the foot pedal.
8. The electric motor will operate and drive the flexible shaft, which in turn rotate the cleaning head. At the same time, water will pass through the machine and out at the end of the casing near the cleaning head.
9. Feed the shaft with cleaning head through tube to clean and loosen deposits inside tube.
10. For bi-direction applications involving internally-spiraled tubes, use spiral brushes only. These spiral brushes have a jam nut on shank to retain itself in shaft during operation. An optional dual foot pedal (#9600-0015) is required for this application.
11. Observe the following operation guidelines:
 - Only feed uncoiled flexible shaft into tube.
 - Do not force cleaning head within tube. If any resistance is felt, back off two inches or so and re-feed shaft until it moves easily through the tube. If this fails, use a smaller cleaning head or one intended for plugged tube application.
 - Keep bends in shaft minimal and avoid sharp 'S' bend.
 - Do not allow tools to come out of other end of tube.

MAINTENANCE

- Note: Remove the plug from the power outlet before carrying out any adjustment service or maintenance.
- Safety coupling replacement: A 80 in-lb Safety Coupling (#9600-0102) is supplied within the motor connection assembly as standard (Kit includes a spare). This will break if the shaft is overloaded by forcing cleaning tool within the tube. A hook type removal tool (#9600-0055) is supplied for removing this broken unit. Engage the far end of the broken coupling with this tool and pull the coupling out.
- Storage: To store, disconnect water supply hose and foot pedal. Disconnect flexible shaft from machine. Dry out the shaft with an air blast through a hose fitting (optional #9614) attached to large aluminum coupling. Store the tube cleaner in a dry, heated place.
- Lubrication: Periodically, grease ball bearing inside motor connector housing through grease fitting, usually every 200 hours of services.
- Replacement of cords or electrical components: If supply cord is damaged, it must be replaced by a special cord or assembly available from the factory. available from the factory

LIST OF ACCESSORIES

Single Foot Pedal #9600-0059

Dual Foot Pedal #9600-0015

Dolly #9600-0134

Shaft Lubricator #9675-0000

Safety Coupling & Remove Tool #9600-0136

Flexible Shaft & Casing #9720-00xx, #9722-00xx, #9724-00xx, #9726-00xx

Expanding Brushes #9900-x00x, #7000-x00x, #2456-x00x, #2463-x00x (Max. Speed = 1725/min.)

Spiral Brushes #61746-x0xx, #62501-x0xx (Max. Speed = 1725/min.)

PARTS LIST

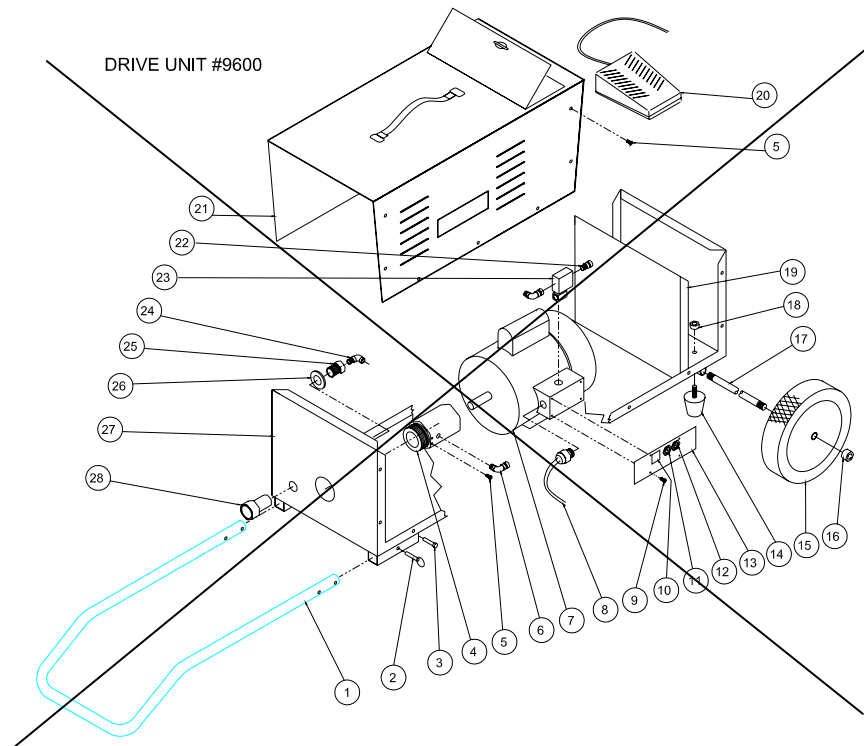

Key	Description	Part No.	Qty
1	Dolly Handle	9600-0126	1
2	Pins	9600-0124	2
3	Clevis Pins	9600-0123	2
4	Motor Connector	***	1
5	Pan Head Screw	9600-0037	26
6	Tube Fitting	9600-0011	1
7	Motor Ass'y	***	1
8	GFCI	***	1
9	Screw	9600-0018	4
10	Main Switch	9600-0017	1
11	Air Switch (Alternate)	9600-0014	1
12	Air Switch (Momentary)	9600-0013	1
13	Switch & Harness	***	1
14	Bumper	9600-0053	4

Key	Description	Part No.	Qty
15	Wheels	9600-0125	2
16	Stop Nut	38614-0000	2
17	Axle	9600-0122	1
18	Lock Nut	51885-0001	4
19	Divider	9600-0041	1
20	Foot Pedal	9600-0059	1
21	Cover	9600-0043	1
22	Tube Fitting	9600-0050	1
23	Solenoid Valve	9600-0010	1
24	Pipe Fitting	9540-0000	1
25	Pipe Bushing	9600-0008	1
26	Washer	30577-0000	1
27	Base	9600-0044	1
28	Hose Coupling	9600-0007	1

*** See table on next page

PARTS LIST (CONT')

Key	Description	9600-0000	9602-0000	9602-2250	9602-2260
4	Motor Connector			9600-0106	
7	Motor Assembly	9600-0070	9600-0097	9600-2277	9600-2297
8	GFCI Plug	9592-0000	9592-0000	9592-0220	9592-0220
13	Switch & Harness	9600-0131	9600-0131	9600-0133	9600-0133

Key	Description	9610-0000	9610-2200	9630-0000
4	Motor Connector			9600-0105
7	Motor Assembly	9600-0079	9600-2279	9600-0085
8	GFCI Plug	9592-0000	9592-0221	9592-0221
13	Switch & Harness	9600-0131	9600-0133	9600-0133

TROUBLE-SHOOTING

PROBLEM	CAUSE & SOLUTION
No power or Main Switch not lit up when unit is plugged into power outlet	Power is not on —flip Main switch to ON position GFCI Plug not reset —press reset button on GFCI GFCI Plug defective Main switch defective
Main Switch lit up but motor not turning when activated	Leakage in air-activated switch system —defective Foot Pedal —defective air switches Defective motor Defective wiring in unit
Main Switch lit up & motor hums or runs only in reverse when activated.	Defective air switches —replace air switch
Motor running but Flexible Shaft not turning	Broken Safety Coupling
Motor running but no water output at end of Flexible Shaft	Water supply not turn on Defective Solenoid Valve
Motor running and water drips inside unit	—Worn Teflon seal inside Motor Connector —Leakage in tube or tube fittings
Unit running rough and/or noisy	Lack of lubrication in Motor Connector —grease ball bearings inside Motor Connector through grease fitting through access hole in bottom of unit —replace worn or corroded ball bearings in Motor Connector

SPECIFICATIONS

MODEL	9600-0000	9602-0000	9602-2250	9602-2260
VOLTAGE	110	110	220	220
FREQUENCY	50/60	60	50	60
HORSE-POWER	1/2	1/2	1/2	1/2
RPM	1725	3450	3450	3450

MODEL	9610-0000	9610-2200	9630-0000
VOLTAGE	110	220	220
FREQUENCY	50/60	50/60	60
HORSE-POWER	1	1	2
RPM	1725	1725	1725

Thomas C. Wilson, Inc.

21-11 44th Avenue, Long Island City, New York 11101
 Tel: (718)729-3360 Fax: (718)361-2872 <http://www.tcwilson.com>
 Email: tcwilson@tcwilson.com