



9715-1055  
9716-1055  
9715-1155  
9716-1155

## **POWER-SOOT VAC INDUSTRIAL VACUUM CLEANER**



### **OPERATING INSTRUCTIONS & SERVICE MANUAL**

Rev: A, 2/22/2007

**TO REDUCE THE RISK OF INJURY AND EQUIPMENT DAMAGE  
USER MUST READ AND UNDERSTAND OPERATOR'S MANUAL.**

#### **Thomas C. Wilson, Inc.**

21-11 44th Avenue, Long Island City, New York 11101  
Tel: (718)729-3360 Fax: (718)361-2872 <http://www.tcwilson.com>  
E-mail: [tcwilson@tcwilson.com](mailto:tcwilson@tcwilson.com)

# SAFETY INSTRUCTIONS



## WARNING!

### **READ AND UNDERSTAND ALL INSTRUCTIONS**

Failure to follow all instructions listed below, may result in accident, fire and/or personal injury.

### **SAVE THESE INSTRUCTIONS**

1. Do not leave vacuum cleaner when plugged in. Unplug from outlet when not in use and before servicing.
2. Do not allow vacuum cleaner to be used as a toy. Close attention is necessary when used by or near children.
3. Use only as described in this manual. Use only with recommended attachments.
4. Do not use with damaged cord or plug. If vacuum cleaner is not working as it should, has been dropped, damaged, left outdoors, or dropped into water, return it to a service center.
5. Do not: pull or carry by cord, use cord as a handle, close a door on cord, or pull cord around sharp edges or corners. Do not run vacuum cleaner over cord. Keep cord away from heated surfaces.
6. Do not unplug by pulling on cord. To unplug, grasp the plug, not the cord.
7. Do not handle plug or appliance with wet hands.
8. Do not put any object into openings. Do not use with any openings blocked. Keep free of dust, lint, hair and anything that may reduce airflow. Poor ventilation will result in overheating of motor.
9. Keep hair, loose clothing, fingers and all parts of body away from openings and moving parts.
10. Do not pick-up anything that is burning or smoking such as: cigarettes, matches or hot ashes, etc.
11. Do not use without appropriate filters in place.
12. Turn off all controls before unplugging.
13. Use extra care when cleaning on stairs.
14. Do not recover flammable or combustible liquids such as gasoline, or use in areas where they may be present.
15. Always turn off vacuum cleaner before connecting or disconnecting motorized power-nozzle.
16. Never operate unit unless the power-head is securely fastened to the recovery tank with latches.
17. Connect to a properly grounded outlet only. See grounding instructions.

# OPERATION

## INSPECTION

Carefully unpack and inspect your vacuum cleaner. Each vacuum cleaner is tested and thoroughly inspected before being shipped; therefore, any damage is the responsibility of the delivering carrier, who should be notified. Read all instructions carefully before operating vacuum cleaner.

## IMPORTANT SAFETY PRECAUTIONS

**WARNING:** If vacuum cleaner is used to recover hazardous substances such as: asbestos, silica, pesticides, etc., the following safety precautions must be taken.

1. Vacuum cleaner must be equipped with an HEPA filter.
2. Service and operation should only be carried out by trained personnel.
3. Dispose of collected materials responsibly. Follow government regulations for the disposal of hazardous materials.

**NOTE:** Any health hazard associated with the use of this vacuum cleaner in conjunction with the recovery of asbestos and other hazardous substances has not been investigated by U.L. (Underwriters Laboratories).

## FIVE STAGES OF FILTRATION

HEPA Vacuum Cleaner systems are equipped with:

1. POLYESTER FILTER WITH GASKET, (PERMANENT, WASHABLE)
2. DRALON SAFETY FILTERS (2), (PERMANENT, WASHABLE)
3. POLYESTER SAFETY FILTERS (2), (TOP FILL ONLY, WASHABLE)
4. HEPA FILTERS (2), (DISPOSABLE)
5. POLYPROPYLENE MESH FILTER WITH GASKET for liquid recovery (PERMANENT, NOT SHOWN)

\* Filters nos.1 and 2 are assembled together and bound by the same gasket.

\*\* Filter no. 5 should never come into contact with any liquids.

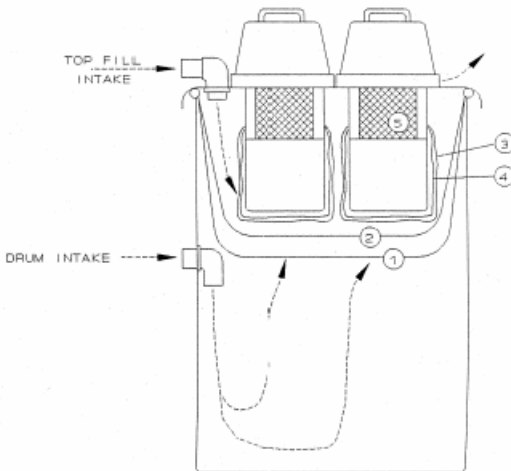

# OPERATION

**WARNING:** If vacuum is to be used to recover designated (hazardous) substances (wet or dry), make sure that filter no.5 (HEPA FILTER) is properly assembled in the HEPA housing and that the housing itself is securely fastened under the vacuum lid with the three hex nuts (see section E “ASSEMBLING AND REPLACING HEPA FILTER”).

## DRY RECOVERY - DRUM INTAKE

- a) Release latches and remove power-head from recovery drum.
- b) Place DRALON/POLYESTER FILTER WITH GASKET (NOS. 1 AND 2) on the recovery drum. Make sure that the filter’s gasket covers the entire circumference of the recovery tank lip.
- c) DRALON SAFETY FILTERS (NO.3) and POLYESTER SAFETY FILTERS (no.4) may remain in place during recovery through drum intake.
- d) Place power-head on recovery drum and fasten latches.
- e) Make sure that the top fill intake is closed. Use the supplied cap to seal top fill suction intake.
- f) Fasten hose to suction intake on side of recovery drum and attach desired tools to hose.
- g) Operate on grounded electrical outlets only (see section F; “GROUNDING INSTRUCTIONS”).

## DRY RECOVERY - TOP FILL INTAKE

- a. Release latches and remove power-head from recovery drum.
- b. Remove DRALON/POLYESTER FILTER WITH GASKET (NOS. 1 AND 2) from the recovery drum.
- c. Place one POLYESTER SAFETY FILTERS (NO.4) around each of the red HEPA housings. Make sure that the filters’ elastics are pulled completely over the HEPA housings.
- d. Place one of the DRALON SAFETY FILTERS (NO.3) over each POLYESTER SAFETY FILTER (NO.4). Make sure that the filters’ elastics are pulled completely over the HEPA housings.
- e. Place power-head on the recovery drum and fasten latches.
- f. Make sure that the drum intake is closed. Use the supplied cap to seal the drum intake.
- g. Fasten hose to the top fill suction intake and attach desired tools to hose.
- h. Operate vacuum cleaner on grounded electrical outlets only (see section F “GROUNDING INSTRUCTIONS”).

# OPERATION

## LIQUID RECOVERY – DRUM INTAKE ONLY

**NOTE:** When recovering liquids, use drum intake only.

- a. Release latches and remove power—head from recovery tank.
- b. Remove DRALON/POLYESTER FILTER WITH GASKET (NOS. 1 AND 2) from the recovery drum.
- c. For liquid recovery, it is recommended that the POLYESTER SAFETY FILTERS (NO.4) be removed and that the DRALON SAFETY FILTERS (NO.3) be kept in place. Make sure to pull the elastic of the DRALON SAFETY FILTERS (NO.3) over the entire HEPA housing.
- d. Clean out inside of the recovery drum.
- e. Place POLYPROPYLENE MESH FILTER (NO.6) on recovery drum. Make sure that the filter's gasket covers the entire circumference of the recovery drum's lip.
- f. Place power-head on recovery drum and fasten latches.
- g. Fasten hose to suction intake on the side of recovery tank and attach desired tools.
- h. Operate on grounded electrical outlets only (see section F; "GROUNDING INSTRUCTIONS").
- i. After wet recovery, empty and dry the inside of recovery drum.

**WARNING:** Do not completely submerge the recovery hose in the fluid. This may cause the recovery tank to overflow due to siphoning action. Hold recovery hose at surface of liquid to allow a mixture of fluid and air to enter the recovery hose. The vacuum machine is not meant to be used as a transfer pump.

**NOTE:** If recovering liquid solutions that foam upon agitation, you must use a defoaming agent. Add the prescribed amount of defoaming agent into the recovery tank in order to avoid the foam from entering the vacuum power unit.

## ASSEMBLING AND REPLACING HEPA FILTERS (NO.5)

1. Unscrew the three hex nuts which hold the HEPA housing to the lid.
2. Remove contaminated filter and substitute it with a new filter of the same configuration.
3. Tightly fasten HEPA housing to lid with three brass nuts. Make sure that all protective gaskets form a perfect seal in and around the HEPA housing.

# PARTS LIST

SM-247

DRY ONLY OR WET & DRY

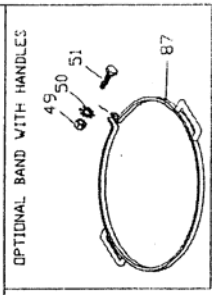
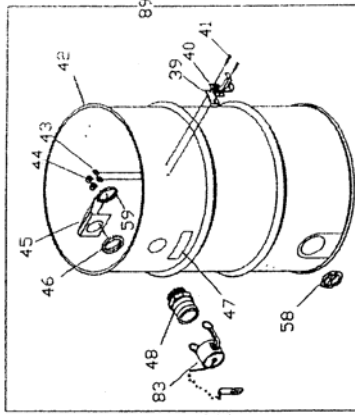
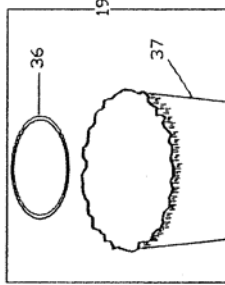
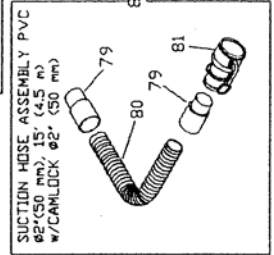
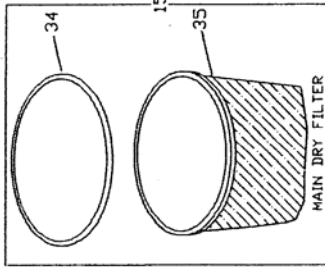
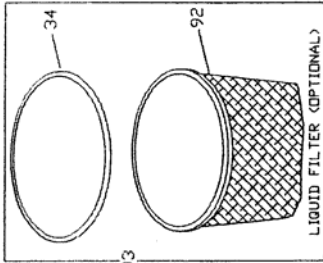
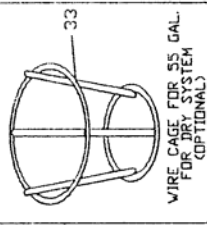
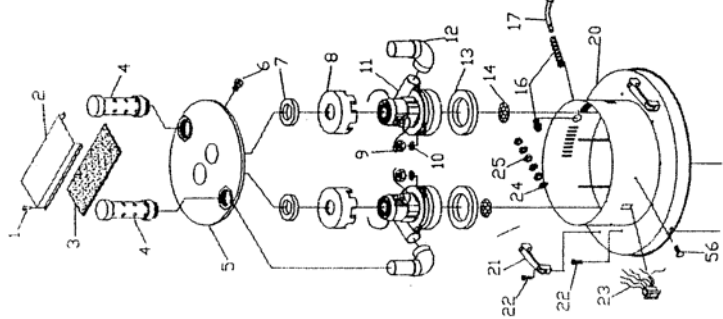
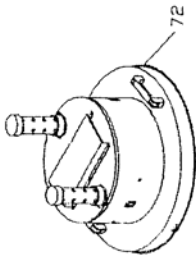
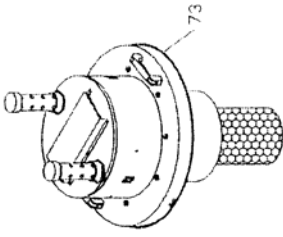

DRAGON PRE-FILTER (OPTIONAL)

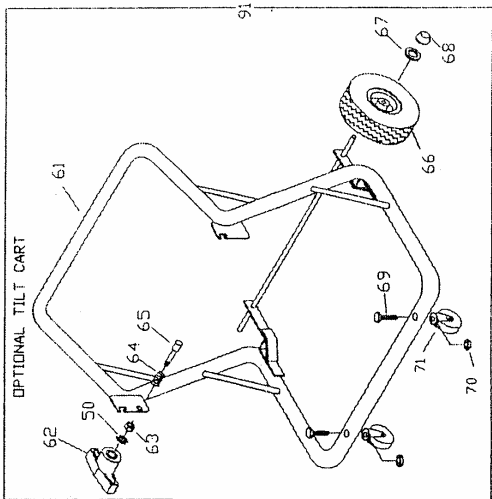
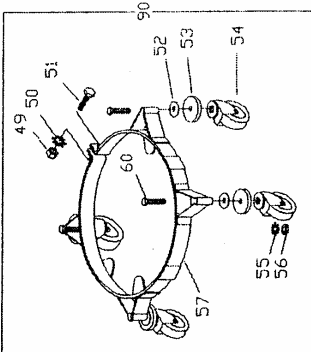
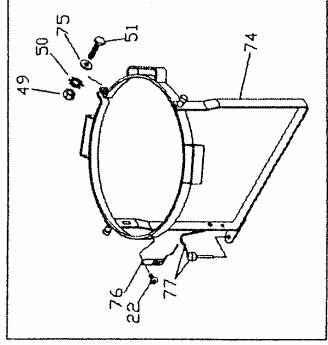
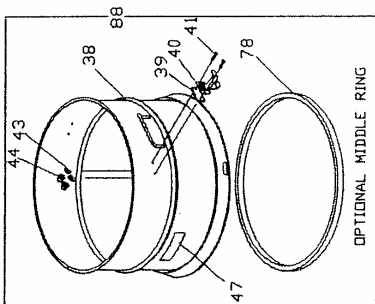
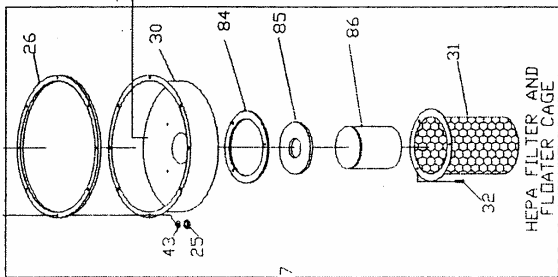
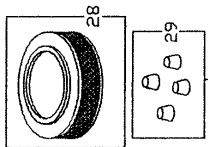

**PARTS LIST**

ITEM	PART#	DESCRIPTION	QTY
1	9715-211535	RIVET	6
2	9715-212437B	DEFLECTOR MOTOR COVER	1
3	9715-213062	FOAM SILENCER	1
4	9715-212440	EXHAUST SILENCER ASSEMBLY	2
5	9715-212438B	TOP LID	1
6	9715-212900	SCREW	6
7	9715-211281	GASKET	2
8	9715-211280A	FOAM SILENCER	2
9	9715-211134	HEX NUT	3
10	9715-211113	LOCK WASHER	2
11	9715-212488	MOTOR G BY-PASS, 120 VOLT	2
12	9715-2 12439	PVC PIPE FITTING	2
13	9715-211027G	GASKET	2
14	9715-213192	SCREEN	2
15	9715-0400	MAIN FILTER ASSEMBLY W/ LACES FOR FILTER CAGE(CAGE SOLD SEPARATELY)	1
16	9715-211323	STRAIN RELIEF	1
17	9715-211188B	POWER CABLE 12/3 25 AMPS MAX	10
18	9715-211325	MALE PLUG, 20 AMPS, 120V	1
19	9715-0500	DRAYLON PREFILTER ASSEMBLY	OPT
20	9715-212436B	LID WITH MOTOR HOUSING	1
21	9715-211203C	HANDLE	2
22	9715-211050	BOLT	11
23	9715-213194	SWITCH, 3 POSITION, 20 AMPS	1
24	9715-211093	LOCK WASHER	3
25	9715-211092	HEX NUT	9
26	9715-213198	GASKET FOR HEPA HOUSING	1
27	97 15-213200	HEPA HOUSING AND FLOATER CAGE ASSEMBLY	OPT
28	9715-213182	HEPA FILTER	OPT
29	9715-212068	RUBBER BUMPER	6
30	9715-213196B	HEPA HOUSING	1
31	9715-211493	FLOATER CAGE	1
32	9715-211129	BOLT	3



**PARTS LIST**

33	9715-212490	WIRE CAGE FOR DRY-ONLY SYSTEM	OPT
34	9715-211102	RING FOR FILTER	1
35A	9715-21133 1A	MAIN FILTER W/ LACES FOR FILTER CAGE	1
35B	9715-211331	MAIN FILTER ONLY	OPT
36	9715-211950	RING FOR FILTER	OPT
37	9715-211329	DRALON PREFILTER	OPT
38	9715-211942B	MIDDLE RING ONLY	OPT
39	9715-211141	LATCH SPACER	6
40	9715-211128	LATCH	6
41	9715-211544	BOLT	12
42	9715-211335	DRUM, STEEL 55 GAL.	1
43	9715-211545	SEAL WASHER	12
44	9715-211131	ACORN HEX NUT	12
45	9715-213 168	DEFLECTOR	OPT
46	9715-211123	GASKET	1
47	9715-211127	LOGO STICKER	2
48	9715-211452A	CAMLOCK MALE PART	1
49	9715-211134	HEX NUT	2
50	9715-211113	LOCK WASHER	4
51	9715-211078	SCREW	3
52	9715-211679B	FLAT WASHER	4
53	9715-211171C	RUBBER BUMPER	4
54	9715-211341A	CASTER 4"	4
55	9715-211689	LOCK WASHER	4
56	9715-211681	HEX NUT	4
57	9715-212422B	4 W CART	1
58	9715-211336	DRAIN TAP	1
59	9715-211318	LOCK NUT	OPT
60	9715-211680	HEX BOLT	4
61	9715-211107B	TILT CART FRAME	OPT
62	9715-211696M	T-KNOB	1
63	9715-211117	HEX NUT	1
64	9715-211116	SPRING	1
65	9715-211115A	LOCK PIN	1
66	9715-211340	WHEEL 10"	2
67	9715-211109	FLAT WASHER	2
68	9715-211403	PUSH NUT CAP	2

**PARTS LIST**

69	9715-211540	HEX BOLT	2
70	9715-211541	HEX NUT NYLOK	2
71	9715-211341A	CASTER 4"	2
72A	9715-0055	POWER HEAD 120V DRY ONLY	-
72B	9716-0055	POWER HEAD 220V DRY ONLY	-
73A	9715-0155	POWER HEAD 120V WET & DRY, NO HEPA	-
73B	9716-0155	POWER HEAD 220V WET & DRY, NO HEPA	-
74	9715-211132B	DRUM SUPPORT	1
75	9715-211130	SEAL WASHER	1
76	9715-211230	CLIP	1
77	9715-211498	PIN	1
78	9715-213070	GASKET	1
79	9715-500137	HOSE CUFF	2
80	9715-500140	HOSE ONLY PVC CRUSHPROOF	15'
81	9715-500163	FEMALE CAMLOCK	1
82	9715-0100	CRUSHPROOF HOSE ASSEMBLY	1
83	9715-211114	STORAGE CAP	1
84	9715-211214	GASKET	1
85	9715-211479	FLOATER GASKET	1
86	9715-211463A	FLOATER	1
87	9715-213064B	BAND	OPT
88A	9715-211945	MIDDLE RING ASSEMBLY, NO SUCTION INTAKE	OPT
88B	9715-211944	MIDDLE RING ASSEMBLY, W/CAMLOCK INTAKE	OPT
89	9715-213066	DRUM ASSEMBLY	1
90	9715-212423	4 WHEEL CART ASSEMBLY	1
91	9715-211334B	TILT CART	OPT
92	9715-211333	LIQUID FILTER ONLY	OPT
93	9715-211017	LIQUID FILTER ASSEMBLY	OPT
94	9715-211317	ELBOW	OPT

## ACCESSORIES



General Purpose Tool Kit #9487-1000 consists of:

9487-3400	Metal Crevice Tool 11"
9498-0000	Wand 2-pc 5-ft
9487-3000	Handi-scrapper Tool 5"
9488-3200	Blower Nozzle

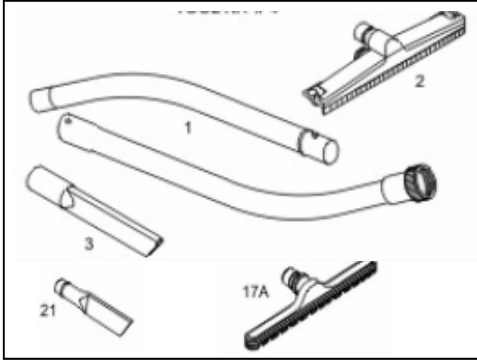

Liquid Pick-Up Tool Kit #9715-0300 consists of:

9715-0700	Wand 2-pc 5-ft
9715-0800	Rubber Squeegee Floor Tool
9715-0900	Plastic Floor Tool 14"
9715-1000	Plastic Crevice Tool 11"
9715-1100	Metal Crevice Tool 11"

## TROUBLE SHOOTING

Symptom	Possible Cause/Corrective Action
<b>Loss of Suction</b>	<ol style="list-style-type: none"> <li>Obstruction in hose or wand -Attached hose to exhaust air orifice</li> <li>Clogged air filter assembly -Tap never-clog bag or wash if necessary.</li> <li>Uneven gasket fit -Reposition or replace gasket.</li> <li>Dented collection can rim -Replace can</li> </ol>
<b>Motor Won't run</b>	<ol style="list-style-type: none"> <li>Blown fuse or tripped circuit -Replace fuse or reset circuit.</li> <li>Defective switch -Replace switch.</li> <li>Defective power cord -Replace power cord.</li> </ol>

# SPECIFICATIONS

MODEL	9715-1055	9716-1055	9715-1155	9716-1155
<b>VOLTAGE</b>	115	220	115	220
<b>FREQUENCY</b>	60	50	60	50
<b>HORSEPOWER</b>	4	4	4	4
<b>AMPS.</b>	21	10.5	21	10.5
<b>STATIC WATER LIFT (INCHES)</b>	110	110	110	110
<b>AIR DISPLACEMENT (CFM)</b>	220	220	220	220
<b>VACUUM MODE</b>	DRY ONLY	DRY ONLY	WET AND DRY	WET AND DRY

## GROUNDING INSTRUCTIONS

**NOTE:** The operator must make certain that the amperage available at the outlet meets or exceeds the vacuum cleaner's amperage rating as specified on the vacuum cleaner's technical data sticker. Failure to verify the power available may result in unsatisfactory operation. Make certain that a suitable plug and outlet are used.

This vacuum cleaner must be grounded. Should it malfunction or breakdown, grounding provides a path of least resistance for electric current to reduce the risk of electric shock. This vacuum cleaner is equipped with a cord having an equipment-grounding conductor and grounding plug. The plug must be plugged into an appropriate outlet that is properly installed and grounded in accordance with all local codes and ordinances.

**WARNING:** Improper connection of the equipment-grounding conductor can result in a risk of electric shock. Check with a qualified electrician or service person if you are in doubt as to whether an outlet is properly grounded. Do not modify the plug provided with the vacuum cleaner. If it will not fit the outlet, have a proper outlet installed by a qualified electrician. No adaptor should be used with this vacuum cleaner.

## Thomas C. Wilson, Inc.

21-11 44th Avenue, Long Island City, New York 11101

Tel: (718)729-3360 Fax: (718)361-2872 <http://www.tcwilson.com>

E-mail: [tcwilson@tcwilson.com](mailto:tcwilson@tcwilson.com)