



75700

## HYDRAULIC TUBE EXTRACTOR COLLET AND SPEAR



### OPERATING INSTRUCTIONS & SERVICE MANUAL

Rev: A, 2/26/2007

TO REDUCE THE RISK OF INJURY AND EQUIPMENT DAMAGE  
USER MUST READ AND UNDERSTAND OPERATOR'S MANUAL.

#### **Thomas C. Wilson, Inc.**

21-11 44th Avenue, Long Island City, New York 11101  
Tel: (718)729-3360 Fax: (718)361-2872 <http://www.tcwilson.com>  
E-mail: [tcwilson@tcwilson.com](mailto:tcwilson@tcwilson.com)



## **WARNING!**

### **READ AND UNDERSTAND ALL INSTRUCTIONS**

Failure to follow all instructions listed below, may result in accident, fire and/or personal injury.

### **SAVE THESE INSTRUCTIONS**

1. **KNOW YOUR POWER TOOL.** Read this service manual carefully.
2. If any safety guards are missing or there are broken or exposed parts, return tool to factory for service.
3. **KEEP WORK AREA CLEAN.** Cluttered areas and benches invite accidents.
4. **AVOID DANGEROUS ENVIRONMENT.** Keep work areas well lit.
6. **STORE IDLE TOOLS.** When not in use, tools should be stored in dry, high or locked-up place – out of reach of children.
7. Do not operate power tools in explosive atmospheres, such as in the presence of flammable liquids, gases, or dust.
8. **WEAR PROPER APPAREL.** No loose clothing or jewelry to get caught in moving parts. Rubber gloves and footwear are recommended when working outdoors.
9. **USE SAFETY GLASSES** with most tools. Also face or dust mask if cutting operation is dusty.
10. **DON'T ABUSE CORD.** Never carry tool by cord or yank it to disconnect from receptacle. Keep cord from heat, oil and sharp edges.
11. **SECURE WORK.** Use clamps or a vise to hold work. It's safer than using your hands to operate tool.
12. **DON'T OVERREACH.** Keep proper footing and balance at all times.
13. **MAINTAIN TOOL WITH CARE.** Keep tools sharp and clean for best and safest performance. Follow instructions for lubricating and changing accessories.
14. **DISCONNECT TOOLS:** When not in use; before servicing; when changing accessories such as blades, bits, cutters, etc.
15. **REMOVE ADJUSTING KEYS AND WRENCHES.** Form habit of checking that keys and adjusting wrenches are removed from tool before turning it on.
16. **AVOID ACCIDENTAL STARTING.** Don't carry plugged-in tool with finger or switch.
17. Disconnect the tool from the air supply before installing, making any adjustment, changing accessories, servicing or storing tool.
18. Do not use unit with combustible fluids or where combustible fluids or fumes may be present
19. Stay clear of loads supported by hydraulics. Do not handle hoses under pressure.
20. Never make or break hydraulic connection while the system is under pressure.
21. The system operating pressure must not exceed the pressure rating of the lowest rated component in the system.
22. **NEVER** set the relief valve to a higher pressure than the maximum rated pressure

# HYDRAULIC TUBE EXTRACTOR KIT

SM-250

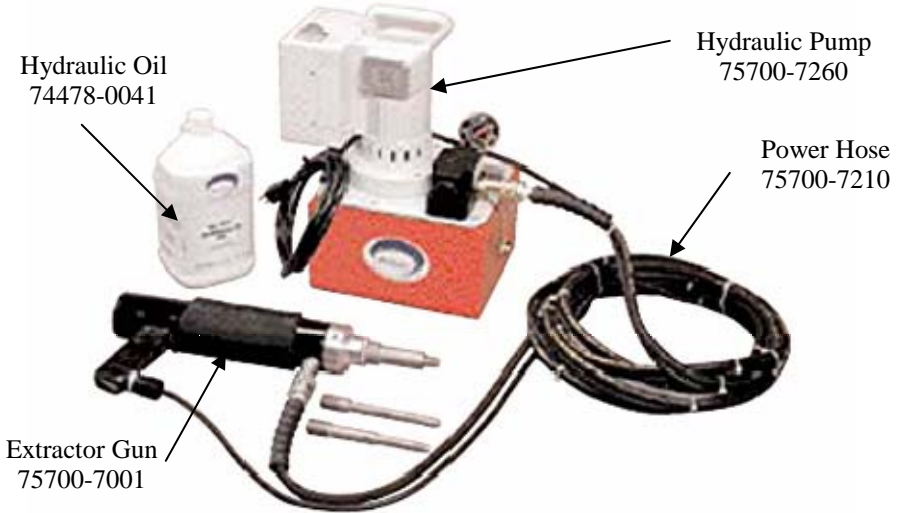

## EXTRACTOR FRONT END PARTS

### 1- COLLET PARTS:

Use to extract 16, 18, 20 & 22 B.W.G tubes

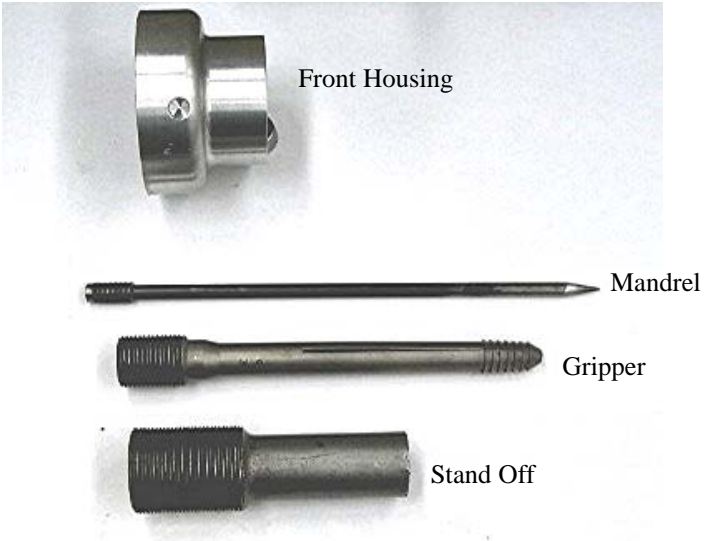

See chart on page 13 for Gripper sets, Mandrels and Standoff part numbers.

## 2- SPEAR PARTS

Use to extract 14, 16, 18 & 19 B.W.G tubes and thick tube sheet.



Mandrel  
75700-7183



Spear Gripper  
75700-7320



Spear  
See chart on page 14 for  
Mandrels part numbers



Spear Driver  
75700-7331



Large Front Housing  
75700-7351



Standoff/depth Stop  
75700-7354



Yoke  
75700-7290

## **SET UP**

The hydraulic tube extractor model 75700 is a precision tool designed for quick and safe removal of tubes from tube sheets.

Major components of the equipment are shown on previous page and consist of the hand held extractor, a high speed hydraulic pump and 15-foot length of hose to connect the extractor pump.

**The hydraulic extractor can be used as a collet puller or a spear puller.**

**Collet type is used to pull light gauge tubes, 16, 18, & 20 GA while the Spear type is used for heavy gauges tubes and thick tube sheets.**

### **Equipment Set-Up**

1. Fill pump tank with hydraulic oil, minimum one gallon to a maximum two gallons. Wilson no. 74478-0041.
2. Uncoil hydraulic hoses and connect quick couplings to the connectors on power unit and the hydraulic ram. Couple them hand-tight.

### **Energize the pump**

There are two electrical switches in the system: one is the trigger on the extractor, the other is an ON-OFF switch on the pump. The pump switch is normally not used and should always be in the OFF position. The pump should run only when the trigger is held down (during the pull stroke). The pump should be off at all other times. To power the pump, plug power cord into 115-volt AC receptacle. If an extension cord is used, it should be grounded and able to handle 20 amps.

### **Pump Pressure Setting**

1. Max. pump pressure should be 10,000 psi. (This is factory set.)
2. Run the cylinder to full stroke and observe the gauge.

# OPERATION

## COLLET TYPE

To operate the extractor with the gripper for light gauges tube pulling, follow this procedure. For Spear type operation go to page 9.

### 1- Gripper set up

a) Select the appropriate gripper from the chart below.

Tube size	Gripper Set	Gripper	Mandrel	Standoff
5/8" x 16-19	5/8" kit 757000062	75700-7055S	75700-7182	75700-7065
5/8" x 16-19		75700-7055M	75700-7182	75700-7065
5/8" x 18-22		75700-7055L	75700-7182	75700-7065
3/4" x 16-18	3/4" kit 75700-0075	75700-7056S	75700-7182	75700-9038
3/4" x 18-20		75700-7056M	75700-7182	75700-9038
3/4" x 19-21		75700-7056MX	75700-7182	75700-9038
3/4" x 20-22		75700-7056L	75700-7182	75700-9038
7/8" x 16-18	7/8" kit 75700-0087	75700-7057S	75700-7183	75700-7067
7/8" x 18-20		75700-7057M	75700-7183	75700-7067
7/8" x 20-22		75700-7057L	75700-7183	75700-7067
1.0" x 16-18	1" kit 75700-0100	75700-7058S	75700-7183	75700-7068
1.0" x 18-20		75700-7058M	75700-7183	75700-7068
1.0" x 20-22		75700-7058L	75700-7183	75700-7068
*1-1/4"x16-19	1-1/4" kit 75700-0125	75700-7355S	75700-7183	75700-7353
*1-1/4"x16-19		75700-7355M	75700-7183	75700-7353
*1-1/4"x16-19		75700-7355L	75700-7183	75700-7353

b) Thread the mandrel into the front of the extractor and tighten with small wrench.



c) Thread the gripper down over the mandrel until just the tip of the mandrel is visible.

Note:

They should fit in the tube smoothly and don't force them in.



d) Adjust standoff/depth stop so that the end of the gripper is flush with the back of the tube sheet.

Note:  
if the tube doesn't come out screw the gripper one-half turn clockwise and repeat if necessary.

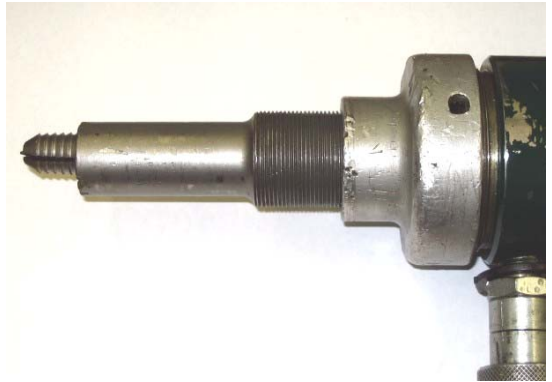

e) cycle the extractor with the trigger switch a few times in free air to purge the system and observe operation.

## **2- Pulling operation**

- a) Insert gripper all the way into the tube with the face of the standoff/depth stop resting flat against the sheet.
- b) Pull the trigger and check if the tube comes out. To extract the tubes with minimum effort and maximum speed, unscrew the gripper one-half turn counterclockwise and repeat if necessary.
- c) If the extractor stalls without removing the tube, make sure the standoff/depth stop is large enough to clear the tube.
- d) Occasionally, brush off chips of metal that build up behind the gripper teeth.
- e) Check location of tooth marks inside tube, for easiest extraction, they should be close to the open end of the tube.
- f) The extractor will draw the tube approximately 2-1/4" clear of the tube sheets. For thicker sheets, additional pulls will be needed using spacer yokes.

## **OPERATION CONT.**

### **SPEAR TYPE**

To operate the extractor with the spears for heavy gauge tubes and thick tube sheets follow this procedure.

1- Remove the front housing from the extractor and thread the large mandrel (P/N 75700-7183) into the front end and tighten.



2- Thread the spear gripper only 3 or 4 turns over the mandrel. Tip of mandrel should be visible at end of gripper. Screw mandrel in or out as necessary to obtain this position.



3- Select proper size spear according to tube size, see page 14.

4- Install large standoff/depth stop into housing only 3 or 4 turns and lock in place with lock ring.





## **OPERATION CONT.**

### **SPEAR TYPE**

5– Drive spear straight into a tube end with a 1/2” or 3/4” impact wrench. Do not drive spear in too tight. Start with a light torque setting and increase slightly until spear is held firmly in tube with minimum torque.

6- Place a yoke (spacer) around sleeve of spear . Clean up any projections on tube sheet so that yoke can lie flat.

7– Insert tip of gripper into sleeve spear and hold against bottom. A gap between standoff/depth stop and yoke is normal.

8– Hold trigger down and pull tube. Release at end of stroke.

9– Add another yoke over the spear, again flat. Be sure the gripper bottom is inside spear before taking a second stroke. Repeat with additional yoke until tube is free.

#### Note:

- Release trigger as soon as possible at the end of each stroke to avoid unnecessary wear and tear on the equipment.
- Experiment with yokes to save strokes. A thicker yoke can be used on the first stroke because of the height of the spear.

# **MAINTENANCE**

## **General**

1. Keep the components clean at all time. Many hydraulic service problems are caused by dirt and/or metallic particles in the hydraulic system. To avoid these problem, the use of proper maintenance including rust prevention and cleanliness will help extend the life of your hydraulic system.
2. Use only an approved clean hydraulic fluid and change fluid as recommend by the manufacturer. Change fluids more often if unit is used under extreme conditions.
3. Change or clean the filter in the system periodically if one is used.

## **Hydraulic Hoses**

1. Hydraulic hoses should be left in carton until needed.
2. Store hoses at a temperature between 50° to 75° F and at a humidity between 20 and 70 percent.
3. Never store hoses in a hot, damp room, in direct sunlight or near heat sources.
4. Do not stack hoses. The weight of the pile will tend to flatten the hose on the bottom. Hanging in a rack is preferred.
5. Do not carry or drag hydraulic assemblies by pulling or pushing on couplings or hoses.

## **Fittings and Couplings**

1. All coupler threads, either male or female, must be kept clean and lubricated regularly. Cover couplers with dust caps when not connected to system. Do not remove covers or plugs until component is ready to be used.
2. Keep dust caps on couplers when not in use. Make certain that all unused couplers are sealed with dust caps/thread protectors.
3. Be sure all hose connections are free of grit and grime.

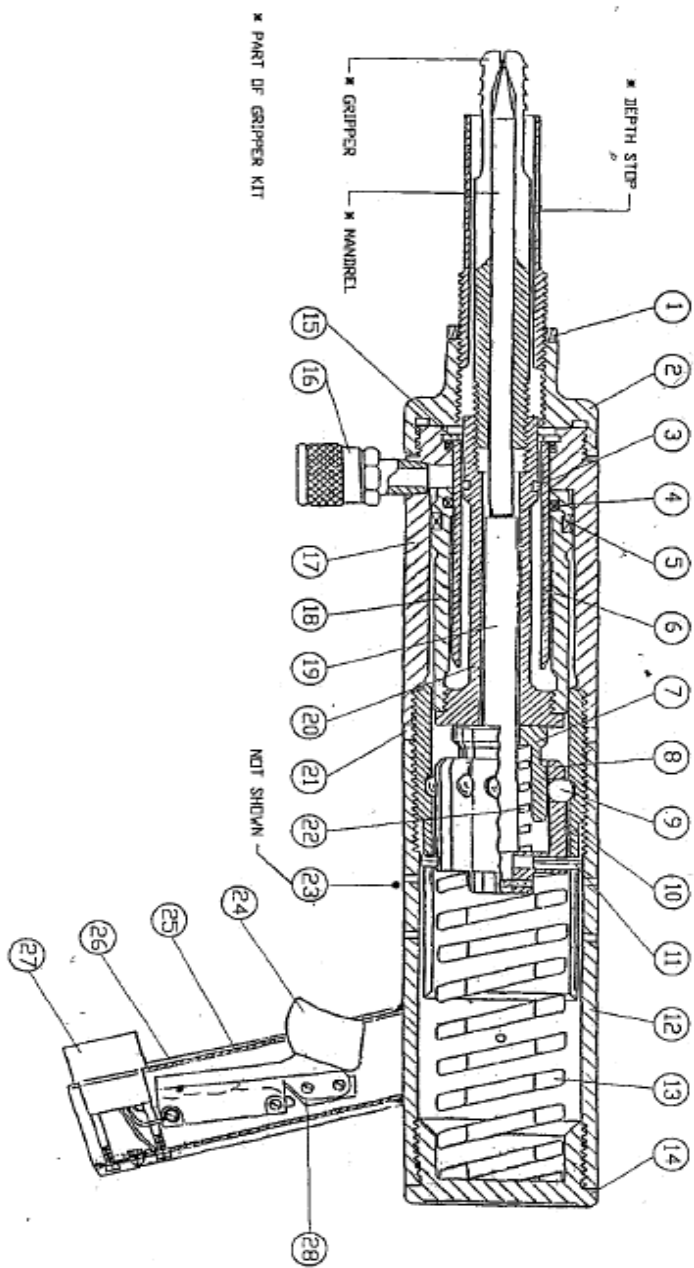

**Model 75700KIT**

Hydraulic Tube Extractor No. 75700-XXXXKIT <b>Consists of:</b>	<b>Part Number</b>
Extractor (for 5/8" to 1" tubes)	75700-7001
Power Hose & wire Assembly	75700-7210
Hydraulic Power Unit (110V-60Hz)	75700-7260
Hydraulic Power Unit (220V-50/60Hz)	75700-7262
Gripper Set (includes Gripper, Mandrel and Standoff, select from chart below)	
To order simply add the tube OD fractional to the kit No.	Example: 75700-1100KIT5/8
For 220V Kit add 220 before the work "KIT"	75700-2200KIT3/4

**COLLET PARTS**

<b>Tube Size</b>	<b>Gripper Set</b>	<b>Gripper</b>	<b>Mandrel</b>	<b>Standoff/ Depth Stop</b>
5/8" x 16-19	5/8" kit 75700-0062	75700-7055S	75700-7182	75700-7065
5/8" x 16-19		75700-7055M	75700-7182	
5/8" x 18-22		75700-7055L	75700-7182	
3/4" x 16-18	3/4" kit 75700-0072	75700-7056S	75700-7182	75700-7066
3/4" x 18-20		75700-7056M	75700-7182	
3/4" x 20-22		75700-7056L	75700-7182	
7/8" x 16-18	7/8" kit 75700-0087	75700-7057S	75700-7183	75700-7067
7/8" x 18-20		75700-7057M	75700-7183	
7/8" x 20-22		75700-7057L	75700-7183	
1.0" x 16-18	1" kit 75700-0100	75700-7058S	75700-7183	75700-7068
1.0" x 18-20		75700-7058M	75700-7183	
1.0" x 20-22		75700-7058L	75700-7183	
1-1/4"x16-19	1-1/4" kit 75700-0125	75700-7355S	75700-7183	75700-7353
1-1/4"x16-19		75700-7355M	75700-7183	
1-1/4"x16-19		75700-7355L	75700-7183	

## **SPEAR PARTS**

**Spear Pulling Kit for 5/8"-3/4" tubes # 75700-6275** includes Large Front Housing, Large Mandrel, Spear Gripper, Spear Drive, Standoff, Yoke and Spears (#75700-7402 and 75700-7403).

<b>Item</b>	<b>Part Number</b>
Spear 0.375-0.500	75700-7401
Spear 0.500-0.625	75700-7402
Spear 0.625-.750	75700-7403
Spear 0.750-0.875	75700-7404
Spear 0.875-1.000	75700-7405
Spear 1.000-1.125	75700-7411
Spear 1.125-1.250	75700-7412
Spear Driver	75700-7331
Spear Gripper	75700-7320
Yoke 1", 1-1/2", 2"	75700-7290
Standoff/Depth stop	75700-7354
Large Front Housing	75700-7351
Large Mandrel	75700-7183

**ACCESSORIES**

<b>Item</b>	<b>Part Number</b>
Long Reach Extension	75700-7001
Extended Mandrel	75700-7210
Extended Depth Stop	75700-7260

Long Reach equipment for 5/8" and 3/4" OD tubes allows extractor to operate close to sidewalls of water boxes.

Standard clear reach is 14". If deeper, specify the above.

## **SPECIFICATIONS**

Electric Power Source: 15 Amp 115 V. Also available in 220V/50Hz.

Operating pressure: 0-10,000 psi

Max. Operating Temperature: 150 deg. F.

Motor Rating: 1-1/8 HP

Flow Rate: 55 CFM of oil at 10,000 PSI with 115 Volt.

Pump Weight: 79 lbs.

Extractor Weight: 20 lbs.

### **Thomas C. Wilson, Inc.**

21-11 44th Avenue, Long Island City, New York 11101

Tel: (718)729-3360 Fax: (718)361-2872 <http://www.tcwilson.com>

E-mail: [tcwilson@tcwilson.com](mailto:tcwilson@tcwilson.com)